

DELIVERY SPECIFICATION

SPEC. No. A-LSoft-g

D A T E : Oct., 2021

To

Non-Controlled Copy

CUSTOMER'S PRODUCT NAME	TDK PRODUCT NAME MULTILAYER CERAMIC CHIP CAPACITORS (Soft Termination) Tape packaging 【RoHS compliant】 CNA5, CNA6 Type X7R Characteristics
-------------------------	--

Please return this specification to TDK representatives with your signature.
If orders are placed without returned specification, please allow us to judge that specification is accepted by your side.

RECEIPT CONFIRMATION

DATE: YEAR MONTH DAY

Test conditions in this specification based on AEC-Q200 for automotive application.

TDK Corporation

Sales

Electronic Components

Sales & Marketing Group

Engineering

Electronic Components Business Company

Ceramic Capacitors Business Group

APPROVED	Person in charge

APPROVED	CHECKED	Person in charge

SCOPE

This delivery specification shall be applied to Multilayer ceramic chip capacitors to be delivered to _____.

PRODUCTION PLACES

Production places defined in this specification shall be TDK Corporation, TDK(Suzhou)Co.,Ltd and TDK Components U.S.A.,Inc.

PRODUCT NAME

The name of the product to be defined in this specifications shall be CNA◇◇◇○○○△△□□×T※※※A.

REFERENCE STANDARD

JIS C 5101-1 : 2010	Fixed capacitors for use in electronic equipment-Part 1: Generic specification
C 5101-22 : 2014	Fixed capacitors for use in electronic equipment-Part22 : Sectional specification : Fixed surface mount multilayer capacitors of ceramic dielectric,Class 2
C 0806-3 : 2014	Packaging of components for automatic handling - Part 3: Packaging of surface mount components on continuous tapes
JEITA RCR-2335 C 2014	Safety application guide for fixed ceramic capacitors for use in electronic equipment

CONTENTS

1. CODE CONSTRUCTION	11. SOLDERING CONDITION
2. OPERATING TEMPERATURE RANGE	12. CAUTION
3. STORING CONDITION AND TERM	13. TAPE PACKAGING SPECIFICATION
4. P.C. BOARD	
5. INDUSTRIAL WASTE DISPOSAL	
6. PERFORMANCE	
7. INSIDE STRUCTURE AND MATERIAL	
8. CAUTION FOR PRODUCTS WITH SOFT TERMINATION	
9. PACKAGING	
10. RECOMMENDATION	

<EXPLANATORY NOTE>

When the mistrust in the spec arises, this specification is given priority. And it will be confirmed by written spec change after conference of both posts involved.

This specification warrants the quality of the ceramic chip capacitor. Capacitors should be evaluated or confirmed a state of mounted on your product.

If the use of the capacitors goes beyond the bounds of this specification, we can not afford to guarantee.

Division	Date	SPEC. No.
Ceramic Capacitors Business Group	October, 2021	A-LSoft-g

1. CODE CONSTRUCTION

(Example) $\frac{\text{CN}}{(1)}$ $\frac{\text{A}}{(2)}$ $\frac{6}{(3)}$ $\frac{\text{P}}{(4)}$ $\frac{1}{(5)}$ $\frac{\text{X7R}}{(6)}$ $\frac{1\text{ H}}{(7)}$ $\frac{106}{(8)}$ $\frac{\text{K}}{(9)}$ $\frac{\text{T}}{(10)}$ $\frac{\text{※※※A}}{(11)}$

(1) Series

Symbol	Series
CN	Soft Termination CN series

(2) Application

Symbol	Application
A	For automotive application

(3) Case size

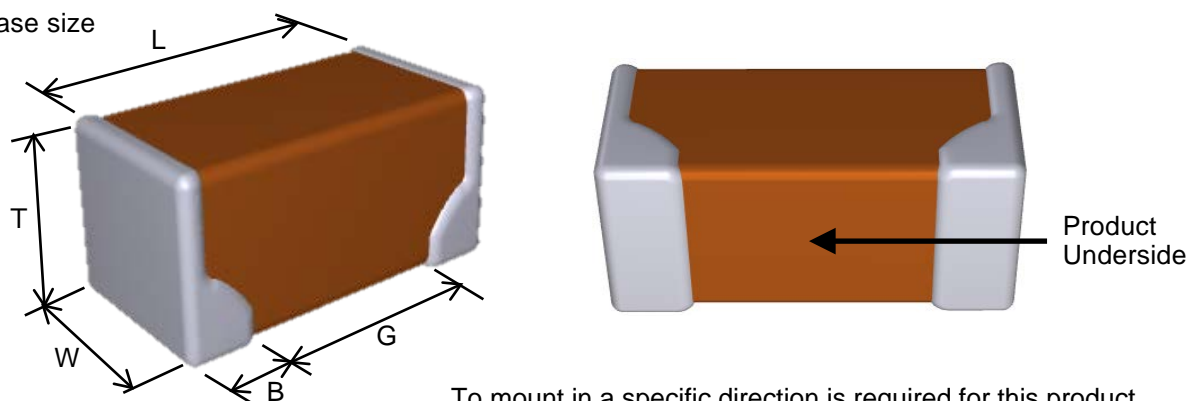

To mount in a specific direction is required for this product.
Please mount products underside on a substrate.

Case size Symbol	Type (EIA style)	Dimensions (Unit : mm)				
		L	W	T	B	G
5	CNA5 (CC1206)	3.20 ^{+0.30} _{-0.20}	1.60 ^{+0.30} _{-0.20}	1.60 ^{+0.30} _{-0.20}	0.30 min.	1.00 min.
6	CNA6 (CC1210)	3.20±0.30	2.50±0.20	2.50±0.20	0.50 min.	—
			2.50±0.30	2.50±0.30		

*As for each item, please refer to detail page on TDK web..

(4) Thickness

Symbol	Dimension(mm)
L	1.60
P	2.50

(5) Voltage condition in the life test

* Details are shown in Table1 No.15 at 6.PERFORMANCE.

Symbol	Condition
1	Rated Voltage

(6) Temperature Characteristics

* Details are shown in Table 1 No.6 at 6.PERFORMANCE.

(7) Rated Voltage

Symbol	Rated Voltage
2 A	DC 100 V
1 N	DC 75 V
1 H	DC 50 V
1 E	DC 25 V
1 C	DC 16 V

(8) Rated Capacitance

Stated in three digits and in units of pico farads (pF).
The first and Second digits identify the first and second significant figures of the capacitance, the third digit identifies the multiplier.

(Example)

Symbol	Rated Capacitance
106	10,000,000 pF

(9) Capacitance tolerance

Symbol	Tolerance
K	± 10 %
M	± 20 %

(10) Packaging

Symbol	Packaging
T	Taping

(11) TDK internal code

2. OPERATING TEMPERATURE RANGE

Min. operating Temperature	Max. operating Temperature	Reference Temperature
-55°C	125°C	25°C

3. STORING CONDITION AND TERM

Storing temperature	Storing humidity	Storing term
5~40°C	20~70%RH	Within 6 months upon receipt.

4. P.C. BOARD

When mounting on an aluminum substrate, CNA6[CC1210] type is more likely to be affected by heat stress from the substrate.

Please inquire separate specification when mounted on the substrate.

5. INDUSTRIAL WASTE DISPOSAL

Dispose this product as industrial waste in accordance with the Industrial Waste Law.

6. PERFORMANCE

Table 1

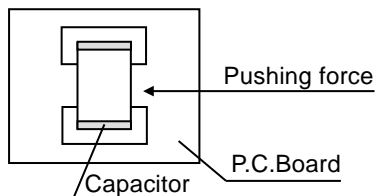
No.	Item	Performance	Test or inspection method										
1	External Appearance	No defects, which may affect performance.	Inspect with magnifying glass (3x)										
2	Insulation Resistance	500MΩ·μF min. (As for the capacitors of rated voltage 16V DC, 100MΩ·μF min.)	Measuring voltage : Rated voltage Voltage application time : 60s.										
3	Voltage Proof	Withstand test voltage without insulation breakdown or other damage.	Apply voltage : 2.5 × rated voltage Voltage application time : 1s. Charge / discharge current : 50mA or lower										
4	Capacitance	Within the specified tolerance.	<table border="1"> <thead> <tr> <th>Capacitance</th> <th>Measuring frequency</th> <th>Measuring voltage</th> </tr> </thead> <tbody> <tr> <td>10uF and under</td> <td>1kHz±10%</td> <td>1.0±0.2Vrms</td> </tr> <tr> <td>Over 10uF</td> <td>120Hz±20%</td> <td>0.5±0.2Vrms.</td> </tr> </tbody> </table>	Capacitance	Measuring frequency	Measuring voltage	10uF and under	1kHz±10%	1.0±0.2Vrms	Over 10uF	120Hz±20%	0.5±0.2Vrms.	
Capacitance	Measuring frequency	Measuring voltage											
10uF and under	1kHz±10%	1.0±0.2Vrms											
Over 10uF	120Hz±20%	0.5±0.2Vrms.											
5	Dissipation Factor	Please refer to detail page on TDK web.	See No.4 in this table for measuring condition.										
6	Temperature Characteristics of Capacitance	<p style="text-align: center;">Capacitance Change (%)</p> <hr/> <p style="text-align: center;">No voltage applied</p> <hr/> <p style="text-align: center;">X7R: ± 15</p> <hr/>	<p>Capacitance shall be measured by the steps shown in the following table, after thermal equilibrium is obtained for each step. ΔC be calculated ref. STEP3 reading.</p> <table border="1"> <thead> <tr> <th>Step</th> <th>Temperature (°C)</th> </tr> </thead> <tbody> <tr> <td>1</td> <td>25 ± 2</td> </tr> <tr> <td>2</td> <td>-55 ± 2</td> </tr> <tr> <td>3</td> <td>25 ± 2</td> </tr> <tr> <td>4</td> <td>125 ± 2</td> </tr> </tbody> </table> <p>As for measuring voltage, please contact with our sales representative.</p>	Step	Temperature (°C)	1	25 ± 2	2	-55 ± 2	3	25 ± 2	4	125 ± 2
Step	Temperature (°C)												
1	25 ± 2												
2	-55 ± 2												
3	25 ± 2												
4	125 ± 2												
7	Robustness of Terminations	No sign of termination coming off, breakage of ceramic, or other abnormal signs.	<p>Reflow solder the capacitors on a P.C.Board shown in Appendix 2. Apply a pushing force gradually at the center of a specimen in a horizontal direction of P.C.board. Pushing force : 17.7N Holding time : 10±1s.</p> 										

(continued)

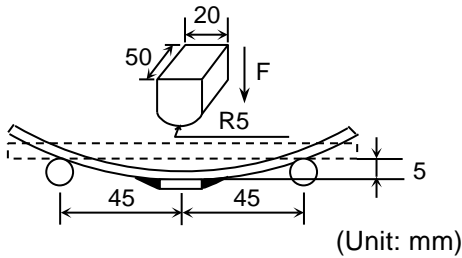
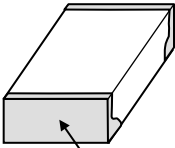
No.	Item	Performance	Test or inspection method														
8	Bending	No crack in the ceramic body.	<p>Reflow solder the capacitor on a P.C.Board shown in Appendix 1.</p>  <p>(Unit: mm)</p>														
9	Solderability	<p>New solder to cover over 75% of termination.</p> <p>25% may have pinholes or rough spots but not concentrated in one spot.</p> <p>Ceramic surface of A sections shall not be exposed due to melting or shifting of termination material.</p>  <p>A section</p>	<p>Solder : Sn-3.0Ag-0.5Cu</p> <p>Flux : Isopropyl alcohol (JIS K 8839) Rosin (JIS K 5902) 25% solid solution.</p> <p>Solder temp. : 245±5°C</p> <p>Dwell time : 3±0.3s.</p> <p>Solder position : Until both terminations are completely soaked.</p>														
10	Resistance to solder heat	<table border="1"> <tr> <td>External appearance</td> <td>No cracks are allowed and terminations shall be covered at least 60% with new solder.</td> </tr> <tr> <td>Capacitance</td> <td> <table border="1"> <thead> <tr> <th>Characteristics</th> <th>Change from the value before test</th> </tr> </thead> <tbody> <tr> <td>X7R</td> <td>± 7.5 %</td> </tr> </tbody> </table> </td> </tr> <tr> <td>D.F.</td> <td>Meet the initial spec.</td> </tr> <tr> <td>Insulation resistance</td> <td>Meet the initial spec.</td> </tr> <tr> <td>Voltage proof</td> <td>No insulation breakdown or other damage.</td> </tr> </table>	External appearance	No cracks are allowed and terminations shall be covered at least 60% with new solder.	Capacitance	<table border="1"> <thead> <tr> <th>Characteristics</th> <th>Change from the value before test</th> </tr> </thead> <tbody> <tr> <td>X7R</td> <td>± 7.5 %</td> </tr> </tbody> </table>	Characteristics	Change from the value before test	X7R	± 7.5 %	D.F.	Meet the initial spec.	Insulation resistance	Meet the initial spec.	Voltage proof	No insulation breakdown or other damage.	<p>Solder : Sn-3.0Ag-0.5Cu</p> <p>Flux : Isopropyl alcohol (JIS K 8839) Rosin (JIS K 5902) 25% solid solution.</p> <p>Solder temp. : 260±5°C</p> <p>Dwell time : 10±1s.</p> <p>Solder position : Until both terminations are completely soaked.</p> <p>Pre-heating : Temp. — 110~140°C Time — 30~60s.</p> <p>Leave the capacitors in ambient condition for 24±2h before measurement.</p>
External appearance	No cracks are allowed and terminations shall be covered at least 60% with new solder.																
Capacitance	<table border="1"> <thead> <tr> <th>Characteristics</th> <th>Change from the value before test</th> </tr> </thead> <tbody> <tr> <td>X7R</td> <td>± 7.5 %</td> </tr> </tbody> </table>	Characteristics	Change from the value before test	X7R	± 7.5 %												
Characteristics	Change from the value before test																
X7R	± 7.5 %																
D.F.	Meet the initial spec.																
Insulation resistance	Meet the initial spec.																
Voltage proof	No insulation breakdown or other damage.																

(continued)

No.	Item		Performance	Test or inspection method															
11	Vibration	External appearance	No mechanical damage.	<p>Applied force : 5G max. Frequency : 10~2,000Hz Reciprocating sweep time : 20 min. Cycle : 12 cycles in each 3 mutually perpendicular directions.</p> <p>Reflow solder the capacitors on a P.C.Board shown in Appendix 2 before testing.</p>															
		Capacitance	Characteristics		Change from the value before test														
			X7R		± 7.5 %														
		D.F.	Meet the initial spec.																
12	Temperature cycle	External appearance	No mechanical damage.	<p>Expose the capacitors in the condition step1 through step 4 listed in the following table.</p> <p>Temp. cycle : 1,000 cycles</p> <table border="1"> <thead> <tr> <th>Step</th> <th>Temperature (°C)</th> <th>Time (min.)</th> </tr> </thead> <tbody> <tr> <td>1</td> <td>-55 ± 3</td> <td>30 ± 3</td> </tr> <tr> <td>2</td> <td>Reference temp.</td> <td>2 ~ 5</td> </tr> <tr> <td>3</td> <td>125 ± 2</td> <td>30 ± 2</td> </tr> <tr> <td>4</td> <td>Reference temp.</td> <td>2 ~ 5</td> </tr> </tbody> </table> <p>Leave the capacitors in ambient condition for 24±2h before measurement.</p> <p>Reflow solder the capacitors on a P.C.Board shown in Appendix 2 before testing.</p>	Step	Temperature (°C)	Time (min.)	1	-55 ± 3	30 ± 3	2	Reference temp.	2 ~ 5	3	125 ± 2	30 ± 2	4	Reference temp.	2 ~ 5
		Step	Temperature (°C)		Time (min.)														
		1	-55 ± 3		30 ± 3														
		2	Reference temp.		2 ~ 5														
		3	125 ± 2		30 ± 2														
		4	Reference temp.		2 ~ 5														
Capacitance	Characteristics	Change from the value before test																	
	X7R	Please contact with our sales representative.																	
D.F.	Meet the initial spec.																		
Insulation resistance	Meet the initial spec.																		
Voltage proof	No insulation breakdown or other damage.																		
13	Moisture Resistance (Steady State)	External appearance	No mechanical damage.	<p>Test temp. : 40±2°C Test humidity : 90~95%RH</p> <p>Test time : 500 +24,0h</p> <p>Leave the capacitors in ambient condition for 24±2h before measurement.</p> <p>Reflow solder the capacitors on a P.C.Board shown in Appendix2 before testing.</p>															
		Capacitance	Characteristics		Change from the value before test														
			X7R		Please contact with our sales representative.														
		D.F.	200% of Initial spec max.																
Insulation resistance	50MΩ·μF min. (As for the capacitors of rated voltage 16V DC, 10MΩ·μF min.)																		

(continued)

No.	Item		Performance	Test or inspection method	
14	Moisture Resistance	External appearance	No mechanical damage.	Test temp. : $85\pm 2^{\circ}\text{C}$ Test humidity : 85%RH Applied voltage : Rated voltage Test time : 1,000 +48,0h Charge/discharge current : 50mA or lower Leave the capacitors in ambient condition for $24\pm 2\text{h}$ before measurement. Reflow solder the capacitors on a P.C.Board shown in Appendix2 before testing. Initial value setting Voltage conditioning 《After voltage treat the capacitors under testing temperature and voltage for 1 hour,》 leave the capacitors in ambient condition for $24\pm 2\text{h}$ before measurement. Use this measurement for initial value.	
		Capacitance	Characteristics		Change from the value before test
			X7R		Please contact with our sale representative.
		D.F.	200% of Initial spec max.		
Insulation resistance	25M Ω · μF min. (As for the capacitors of rated voltage 16V DC, 5M Ω · μF min.)				
15	Life	External appearance	No mechanical damage.	Test temp. : $125 \pm 2^{\circ}\text{C}$ Applied voltage : Please contact with our sales representative. Test time : 1,000 +48,0h Charge/discharge current : 50mA or lower Leave the capacitors in ambient condition for $24\pm 2\text{h}$ before measurement. Reflow solder the capacitors on a P.C.Board shown in Appendix2 before testing. Initial value setting Voltage conditioning 《After voltage treat the capacitors under testing temperature and voltage for 1 hour,》 leave the capacitors in ambient condition for $24\pm 2\text{h}$ before measurement. Use this measurement for initial value.	
		Capacitance	Characteristics		Change from the value before test
			X7R		Please contact with our sales representative.
		D.F.	200% of Initial spec max.		
Insulation resistance	50M Ω · μF min. (As for the capacitors of rated voltage 16V DC, 10M Ω · μF min.)				

*As for the initial measurement of capacitors on number 6,10,11,12 and 13 leave capacitors at $150\text{ }0,-10^{\circ}\text{C}$ for 1h and measure the value after leaving capacitors for $24 \pm 2\text{h}$ in ambient condition.

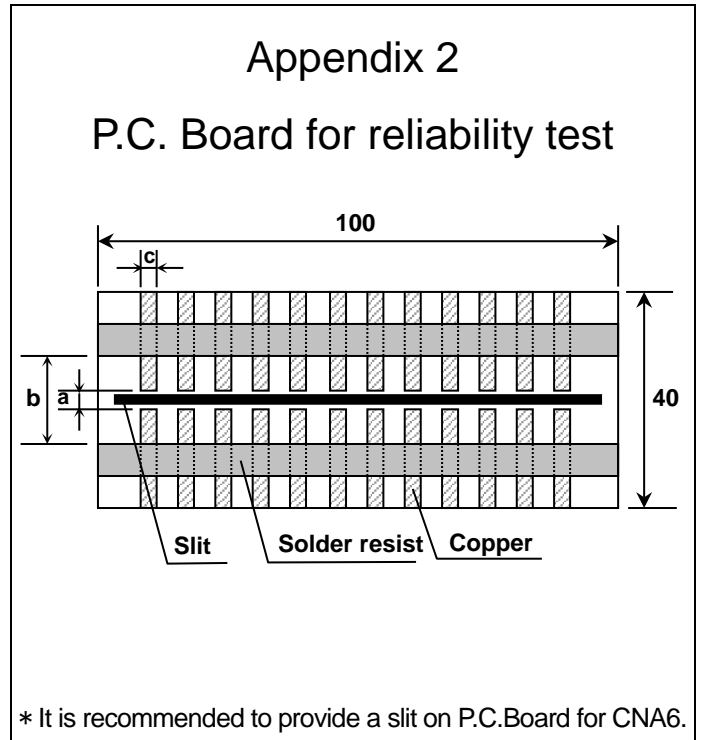
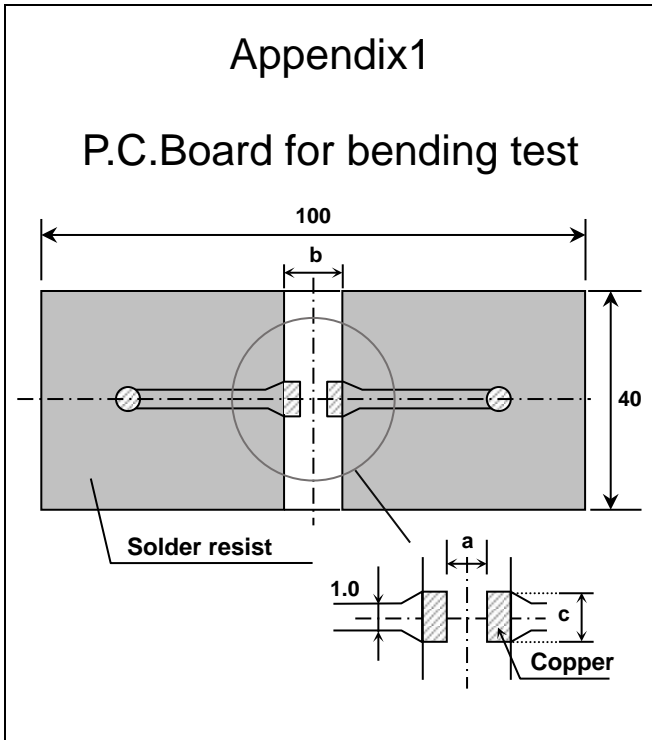

(Unit : mm)

Symbol	Dimensions		
	a	b	c
Case size			
CNA5 (CC1206)	2.2	5.0	2.0
CNA6 (CC1210)	2.2	5.0	2.9

1. Material : Glass Epoxy(As per JIS C6484 GE4)

2. Thickness : 1.6mm

- Copper(Thickness:0.035mm)
- Solder resist

7. INSIDE STRUCTURE AND MATERIAL

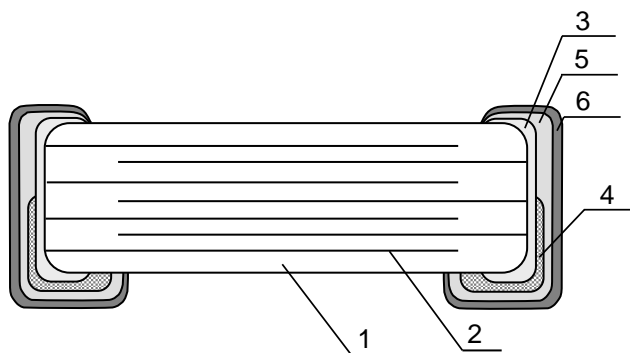

No.	NAME	MATERIAL
1	Dielectric	BaTiO ₃
2	Electrode	Nickel (Ni)
3	Termination	Copper (Cu)
4		Conductive resin (Filler : Ag)
5		Nickel (Ni)
6		Tin (Sn)

8. CAUTION FOR PRODUCTS WITH SOFT TERMINATION

This product contains Ag (Silver) as part of the middle layer of termination. To avoid electromigration of Ag under high temperature and humidity, and failures caused by corrosive gas, chip capacitors on P.C boards should be protected by moisture proof-sealing.

9. PACKAGING

Packaging shall be done to protect the components from the damage during transportation and storing, and a label which has the following information shall be attached.

Tape packaging is as per 13. TAPE PACKAGING SPECIFICATION.

- 1) Inspection No.
- 2) TDK P/N
- 3) Customer's P/N
- 4) Quantity

*Composition of Inspection No.

Example $\frac{F}{(a)} \frac{1}{(b)} \frac{A}{(c)} - \frac{23}{(d)} - \frac{001}{(e)}$

- (a) Line code
- (b) Last digit of the year
- (c) Month and A for January and B for February and so on. (Skip I)
- (d) Inspection Date of the month.
- (e) Serial No. of the day

*Composition of new Inspection No.
(Implemented on and after May 1, 2019 in sequence)

Example

I	F	1	E	2	3	A	0	0	1
(a)	(b)	(c)	(d)	(e)	(f)	(g)			

- (a) Prefix
- (b) Line code
- (c) Last digit of the year
- (d) Month and A for January and B for February and so on. (Skip I)
- (e) Inspection Date of the month.
- (f) Serial No. of the day(00 ~ ZZ)
- (g) Suffix(00 ~ ZZ)

* It was shifted to the new inspection No. on and after May 2019, but the implementation timing may be different depending on shipment bases.

Until the shift is completed, either current or new composition of inspection No. will be applied.

10. RECOMMENDATION

As for CNA6 [CC1210], It is recommended to provide a slit (about 1mm wide) in the board under the components to improve washing Flux. And please make sure to dry detergent up completely before.

11. SOLDERING CONDITION

Reflow soldering only.

12. CAUTION

No.	Process	Condition
1	Operating Condition (Storage, Use, Transportation)	<p>1-1. Storage, Use</p> <p>The capacitors must be stored in an ambient temperature of 5 to 40°C with a relative humidity of 20 to 70%RH. JIS C 60721-3-1 Class 1K2 should be followed for the other climatic conditions.</p> <ol style="list-style-type: none"> 1) High temperature and humidity environment may affect a capacitor's solder ability because it accelerates terminal oxidization. They also deteriorate performance of taping and packaging. Therefore, SMD capacitors shall be used within 6 months. For capacitors with terminal electrodes consisting of silver or silver-palladium which tend to become oxidized or sulfurized, use as soon as possible, such as within one month after opening the bag. 2) When capacitors are stored for a longer time period than 6 months, confirm the solderability of the capacitors prior to use. During storage, keep the minimum packaging unit in its original packaging without opening it. Do not deviate from the above temperature and humidity conditions even for a short term. 3) Corrosive gasses in the air or atmosphere may result in deterioration of the reliability, such as poor solderability of the terminal electrodes. Do not store capacitors where they will be exposed to corrosive gas (e.g., hydrogen sulfide, sulfur dioxide, chlorine ammonia etc.) 4) Solderability and electrical performance may deteriorate due to photochemical change in the terminal electrode if stored in direct sunlight, or due to condensation from rapid changes in humidity. The capacitors especially which use resin material must be operated and stored in an environment free of dew condensation, as moisture absorption due to condensation may affect the performance. 5) Refer to JIS C 60721-3-1, class 1K2 for other climate conditions. <p>1-2. Handling in transportation</p> <p>In case of the transportation of the capacitors, the performance of the capacitors may be deteriorated depending on the transportation condition. (Refer to JEITA RCR-2335C 9.2 Handling in transportation)</p>
2	Circuit design  Caution	<p>2-1. Operating temperature</p> <ol style="list-style-type: none"> 1) Upper category temperature (maximum operating temperature) is specified. It is necessary to select a capacitor whose rated temperature is higher than the operating temperature. Also, it is necessary to consider the temperature distribution in the equipment and seasonal temperature variation. 2) Surface temperature including self heating should be below maximum operating temperature. Due to dielectric loss, capacitors will heat itself when AC is applied due to ESR. Especially at high frequencies, please be careful that the heat might be so extreme. Also, even if the surface temperature of the capacitor includes self-heating and is the maximum operating temperature or lower, excessive heating of the capacitor due to self-heating may cause deterioration of the characteristics and reliability of the capacitor. The self-heating temperature rise of the capacitor changes depending on the difference in heat radiation due to the mounting method to the device, the ambient temperature, the cooling method of the device and circuit board material and the design, etc. The load should be contained so that the self-heating temperature rise of the capacitor body in a natural convection environment at an ambient temperature of 25°C remain below 20°C. <p>When using in a high-frequency circuit or a circuit in which a capacitor generates heat, such as when a high-frequency ripple current flows, pay attention to the above precautions. (Note that accurate measurement may not be possible with self-heating measurement when the equipment applies cooling other than natural convection such as a cooling fan.)</p>

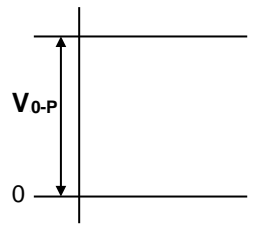
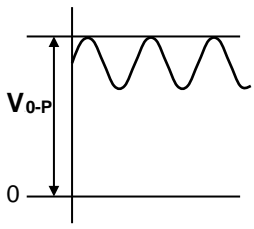
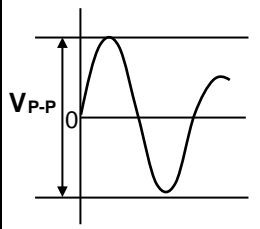
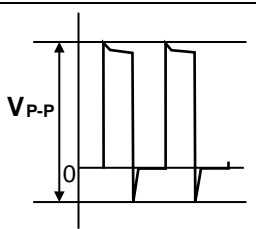
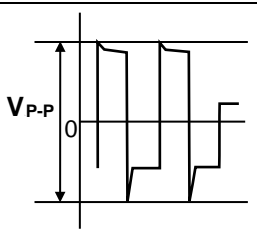
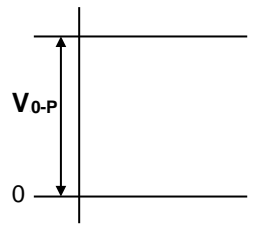
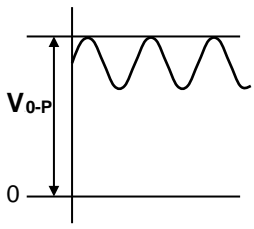
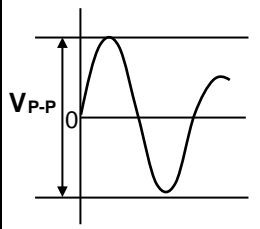
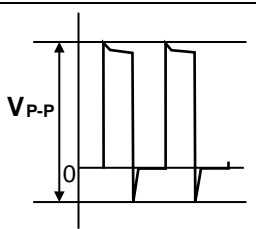
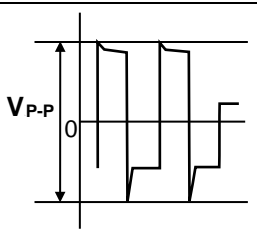
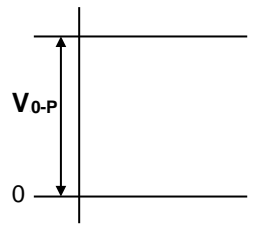
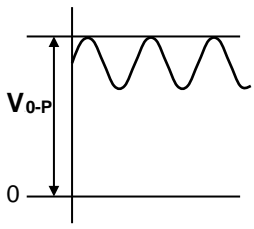
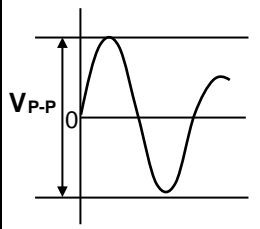
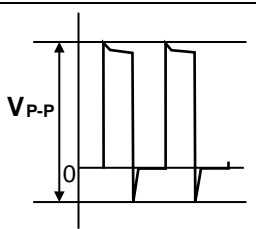
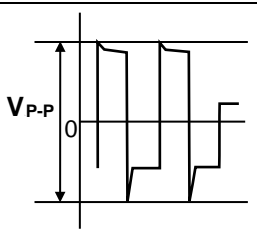
No.	Process	Condition														
2	Circuit design ⚠ Caution	<p>3) The electrical characteristics of the capacitors will vary depending on the temperature. The capacitors should be selected and designed in taking the temperature into consideration.</p> <p>2-2. When overvoltage is applied Applying overvoltage to a capacitor may cause dielectric breakdown and result in a short circuit. The duration until dielectric breakdown depends on the applied voltage and the ambient temperature.</p> <p>2-3. Operating voltage 1) Operating voltage across the terminals should be below the rated voltage. When AC and DC are super imposed, V_{0-P} must be below the rated voltage. — (1) and (2) AC or pulse with overshooting, V_{P-P} must be below the rated voltage. — (3), (4) and (5) When the voltage is started to apply to the circuit or it is stopped applying, the irregular voltage may be generated for a transit period because of resonance or switching. Be sure to use the capacitors within rated voltage containing these Irregular voltage.</p> <table border="1" data-bbox="469 757 1444 1025"> <thead> <tr> <th data-bbox="469 757 659 790">Voltage</th> <th data-bbox="663 757 919 790">(1) DC voltage</th> <th data-bbox="924 757 1179 790">(2) DC+AC voltage</th> <th data-bbox="1184 757 1444 790">(3) AC voltage</th> </tr> </thead> <tbody> <tr> <td data-bbox="469 797 659 1025">Positional Measurement (Rated voltage)</td> <td data-bbox="663 797 919 1025"></td> <td data-bbox="924 797 1179 1025"></td> <td data-bbox="1184 797 1444 1025"></td> </tr> </tbody> </table> <table border="1" data-bbox="469 1055 1182 1328"> <thead> <tr> <th data-bbox="469 1055 659 1088">Voltage</th> <th data-bbox="663 1055 919 1088">(4) Pulse voltage (A)</th> <th data-bbox="924 1055 1182 1088">(5) Pulse voltage (B)</th> </tr> </thead> <tbody> <tr> <td data-bbox="469 1095 659 1328">Positional Measurement (Rated voltage)</td> <td data-bbox="663 1095 919 1328"></td> <td data-bbox="924 1095 1182 1328"></td> </tr> </tbody> </table> <p>2) Even below the rated voltage, if repetitive high frequency AC or pulse is applied, the reliability of the capacitors may be reduced.</p> <p>3) The effective capacitance will vary depending on applied DC and AC voltages. The capacitors should be selected and designed in taking the voltages into consideration.</p> <p>4) Abnormal voltage (surge voltage, static electricity, pulse voltage, etc.) shall not exceed the rated voltage.</p> <p>5) When capacitors are used in a series connection, it is necessary to add a balancing circuit such as voltage dividing resistors in order to avoid an imbalance in the voltage applied to each capacitor.</p> <p>2-4. Frequency When the capacitors (Class 2) are used in AC and/or pulse voltages, the capacitors may vibrate themselves and generate audible sound.</p>	Voltage	(1) DC voltage	(2) DC+AC voltage	(3) AC voltage	Positional Measurement (Rated voltage)				Voltage	(4) Pulse voltage (A)	(5) Pulse voltage (B)	Positional Measurement (Rated voltage)		
Voltage	(1) DC voltage	(2) DC+AC voltage	(3) AC voltage													
Positional Measurement (Rated voltage)																
Voltage	(4) Pulse voltage (A)	(5) Pulse voltage (B)														
Positional Measurement (Rated voltage)																

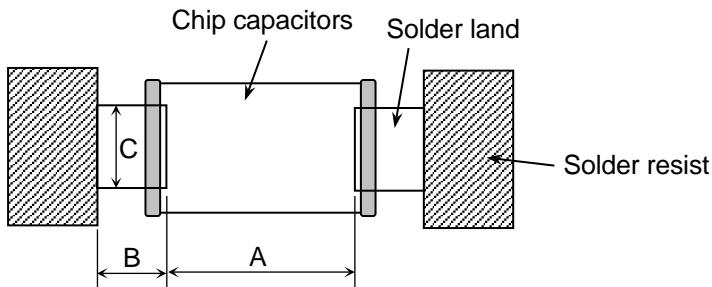
No.	Process	Condition												
3	Designing P.C.board	<p>The amount of solder at the terminations has a direct effect on the reliability of the capacitors.</p> <ol style="list-style-type: none"> 1) The greater the amount of solder, the higher the stress on the chip capacitors, and the more likely that it will break. When designing a P.C.board, determine the shape and size of the solder lands to have proper amount of solder on the terminations. 2) Avoid using common solder land for multiple terminations and provide individual solder land for each terminations. 3) Size and recommended land dimensions. <div style="text-align: center;">  </div> <p style="text-align: center;">Reflow soldering (mm)</p> <table border="1" style="margin-left: auto; margin-right: auto;"> <thead> <tr> <th style="text-align: center;">Case size Symbol</th> <th style="text-align: center;">CNA5 (CC1206)</th> <th style="text-align: center;">CNA6 (CC1210)</th> </tr> </thead> <tbody> <tr> <td style="text-align: center;">A</td> <td style="text-align: center;">2.0 ~ 2.4</td> <td style="text-align: center;">2.0 ~ 2.4</td> </tr> <tr> <td style="text-align: center;">B</td> <td style="text-align: center;">1.0 ~ 1.2</td> <td style="text-align: center;">1.0 ~ 1.2</td> </tr> <tr> <td style="text-align: center;">C</td> <td style="text-align: center;">1.1 ~ 1.6</td> <td style="text-align: center;">1.9 ~ 2.5</td> </tr> </tbody> </table>	Case size Symbol	CNA5 (CC1206)	CNA6 (CC1210)	A	2.0 ~ 2.4	2.0 ~ 2.4	B	1.0 ~ 1.2	1.0 ~ 1.2	C	1.1 ~ 1.6	1.9 ~ 2.5
Case size Symbol	CNA5 (CC1206)	CNA6 (CC1210)												
A	2.0 ~ 2.4	2.0 ~ 2.4												
B	1.0 ~ 1.2	1.0 ~ 1.2												
C	1.1 ~ 1.6	1.9 ~ 2.5												

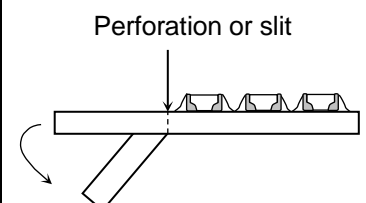
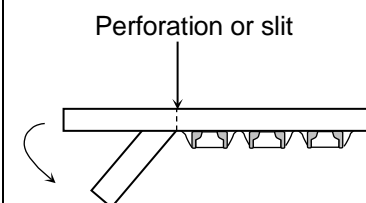
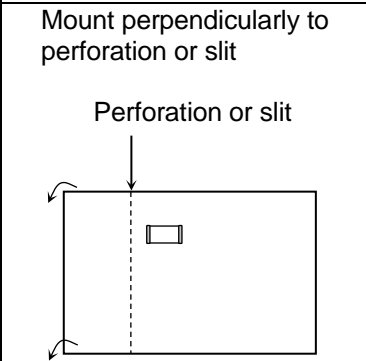
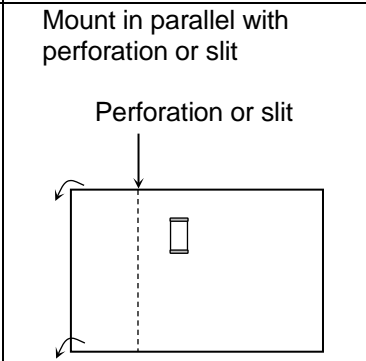
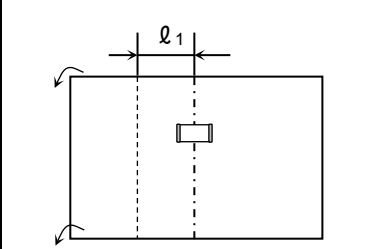
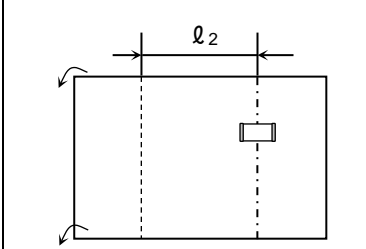
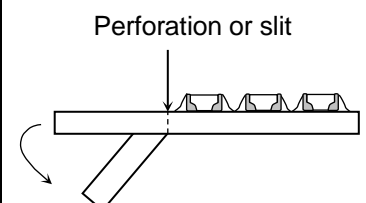
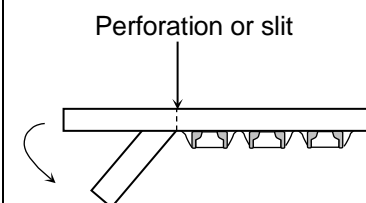
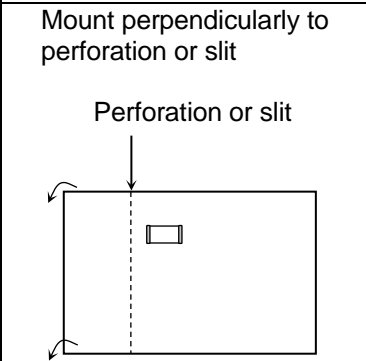
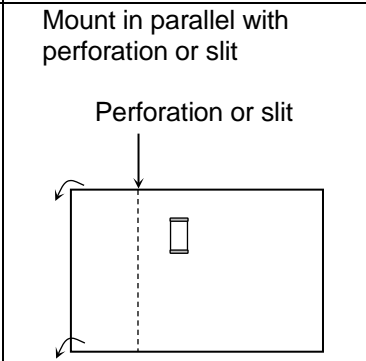
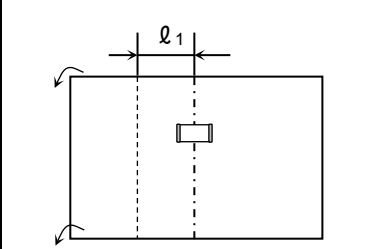
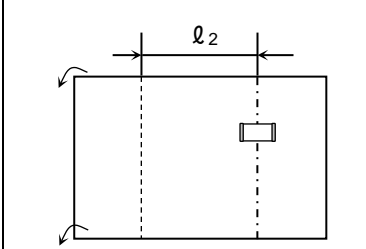
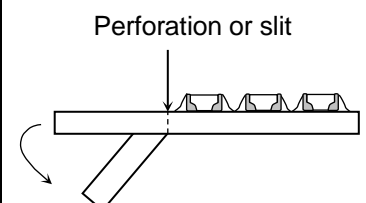
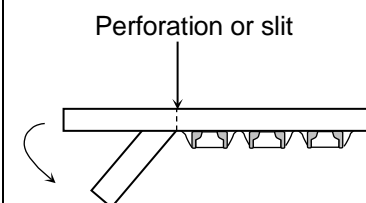
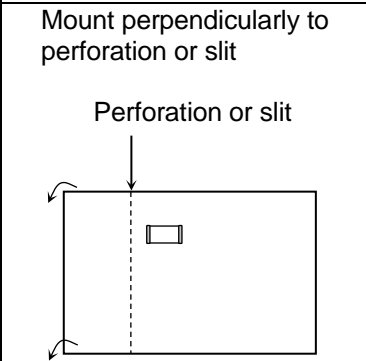
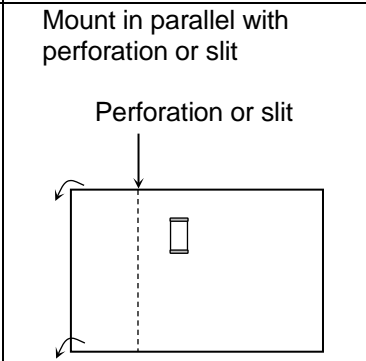
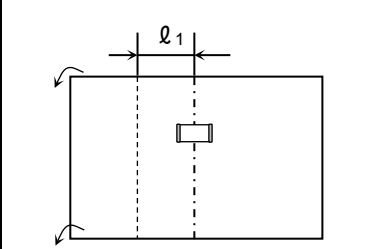
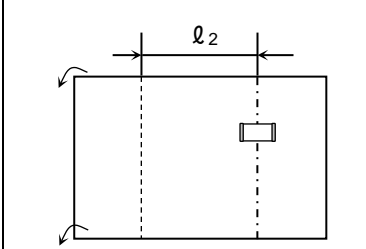
No.	Process	Condition												
3	Designing P.C.board	<p>4) Recommended chip capacitors layout is as following.</p> <table border="1" style="width: 100%; border-collapse: collapse;"> <thead> <tr> <th style="width: 20%;"></th> <th style="width: 40%;">Disadvantage against bending stress</th> <th style="width: 40%;">Advantage against bending stress</th> </tr> </thead> <tbody> <tr> <td style="text-align: center; vertical-align: middle;">Mounting face</td> <td style="text-align: center;"> <p>Perforation or slit</p>  <p>Break P.C.board with mounted side up.</p> </td> <td style="text-align: center;"> <p>Perforation or slit</p>  <p>Break P.C.board with mounted side down.</p> </td> </tr> <tr> <td style="text-align: center; vertical-align: middle;">Chip arrangement (Direction)</td> <td style="text-align: center;"> <p>Mount perpendicularly to perforation or slit</p> <p>Perforation or slit</p>  </td> <td style="text-align: center;"> <p>Mount in parallel with perforation or slit</p> <p>Perforation or slit</p>  </td> </tr> <tr> <td style="text-align: center; vertical-align: middle;">Distance from slit</td> <td style="text-align: center;"> <p>Closer to slit is higher stress</p>  <p>$(l_1 < l_2)$</p> </td> <td style="text-align: center;"> <p>Away from slit is less stress</p>  <p>$(l_1 < l_2)$</p> </td> </tr> </tbody> </table>		Disadvantage against bending stress	Advantage against bending stress	Mounting face	<p>Perforation or slit</p>  <p>Break P.C.board with mounted side up.</p>	<p>Perforation or slit</p>  <p>Break P.C.board with mounted side down.</p>	Chip arrangement (Direction)	<p>Mount perpendicularly to perforation or slit</p> <p>Perforation or slit</p> 	<p>Mount in parallel with perforation or slit</p> <p>Perforation or slit</p> 	Distance from slit	<p>Closer to slit is higher stress</p>  <p>$(l_1 < l_2)$</p>	<p>Away from slit is less stress</p>  <p>$(l_1 < l_2)$</p>
	Disadvantage against bending stress	Advantage against bending stress												
Mounting face	<p>Perforation or slit</p>  <p>Break P.C.board with mounted side up.</p>	<p>Perforation or slit</p>  <p>Break P.C.board with mounted side down.</p>												
Chip arrangement (Direction)	<p>Mount perpendicularly to perforation or slit</p> <p>Perforation or slit</p> 	<p>Mount in parallel with perforation or slit</p> <p>Perforation or slit</p> 												
Distance from slit	<p>Closer to slit is higher stress</p>  <p>$(l_1 < l_2)$</p>	<p>Away from slit is less stress</p>  <p>$(l_1 < l_2)$</p>												

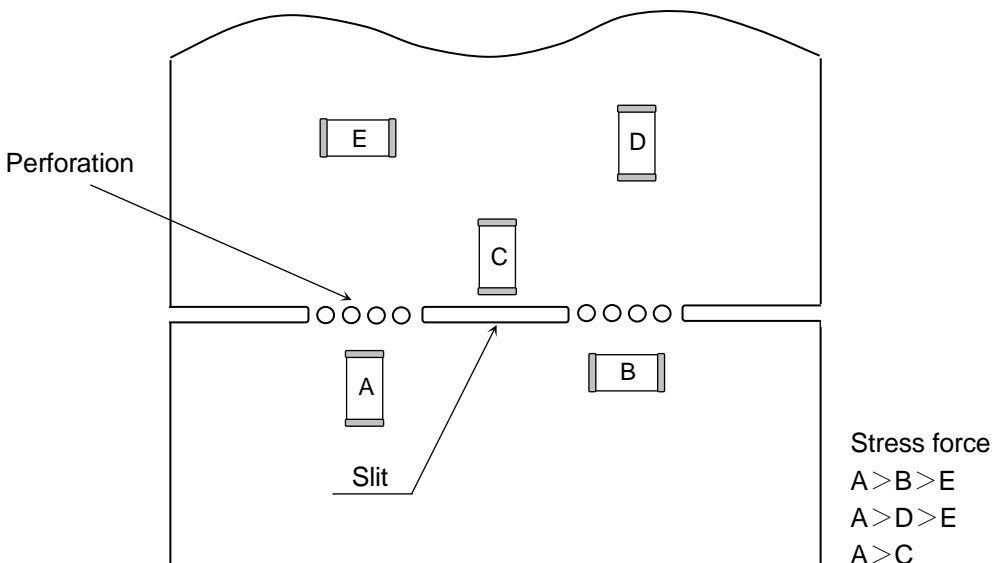
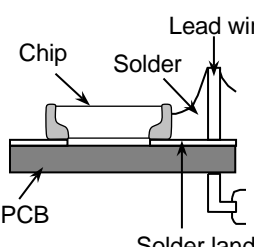
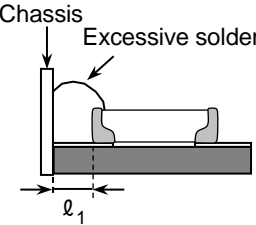
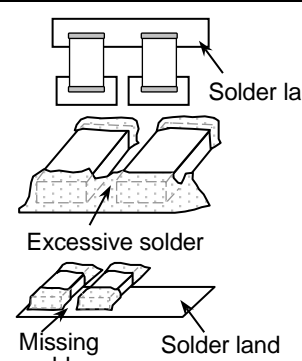
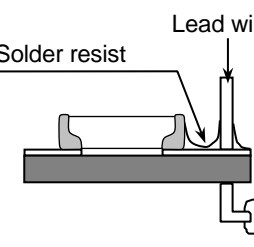
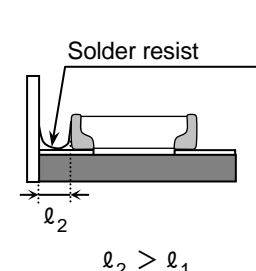
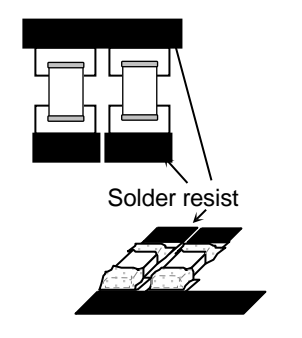
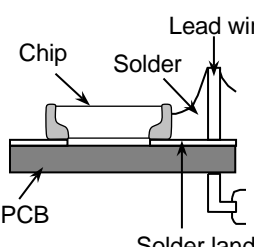
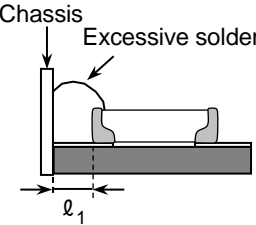
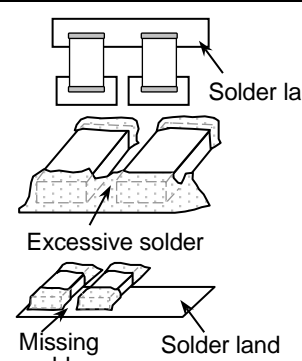
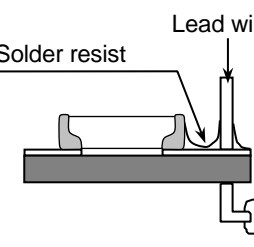
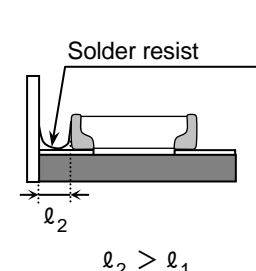
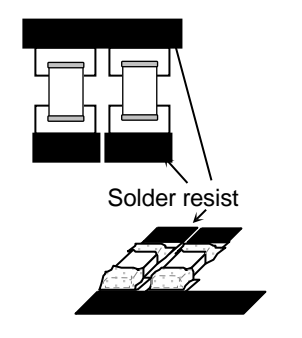
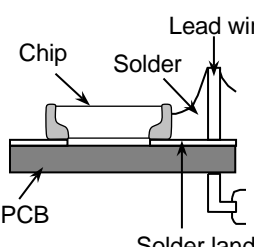
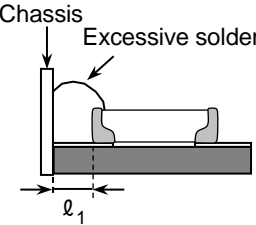
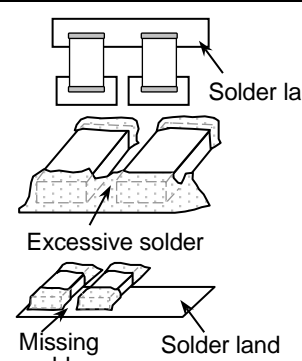
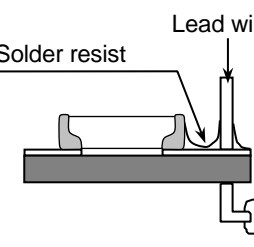
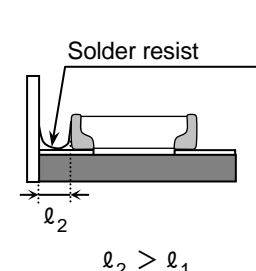
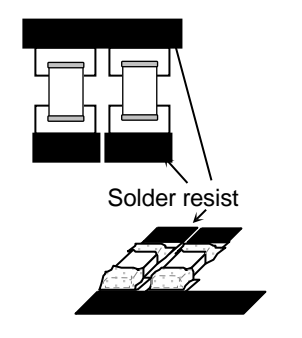
No.	Process	Condition												
3	Designing P.C.board	<p>5) Mechanical stress varies according to location of chip capacitors on the P.C.board.</p>  <p>Stress force $A > B > E$ $A > D > E$ $A > C$</p> <p>When dividing printed wiring boards, the intensities of mechanical stress applied to capacitors are different according to each dividing method in the order of : Push-back < Slit < V-groove < Perforation. Therefore consider not only position of capacitors, but also the way of the dividing the printed wiring boards.</p> <p>6) Layout recommendation</p> <table border="1" data-bbox="375 1041 1481 1960"> <thead> <tr> <th data-bbox="375 1041 539 1160">Example</th> <th data-bbox="539 1041 842 1160">Use of common solder land</th> <th data-bbox="842 1041 1149 1160">Soldering with chassis</th> <th data-bbox="1149 1041 1481 1160">Use of common solder land with other SMD</th> </tr> </thead> <tbody> <tr> <td data-bbox="375 1160 539 1545">Need to avoid</td> <td data-bbox="539 1160 842 1545">  </td> <td data-bbox="842 1160 1149 1545">  </td> <td data-bbox="1149 1160 1481 1545">  </td> </tr> <tr> <td data-bbox="375 1545 539 1960">Recommen Solder land - dation</td> <td data-bbox="539 1545 842 1960">  </td> <td data-bbox="842 1545 1149 1960">  </td> <td data-bbox="1149 1545 1481 1960">  </td> </tr> </tbody> </table>	Example	Use of common solder land	Soldering with chassis	Use of common solder land with other SMD	Need to avoid				Recommen Solder land - dation			
Example	Use of common solder land	Soldering with chassis	Use of common solder land with other SMD											
Need to avoid														
Recommen Solder land - dation														

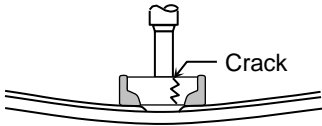
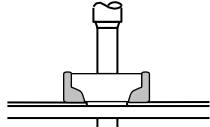
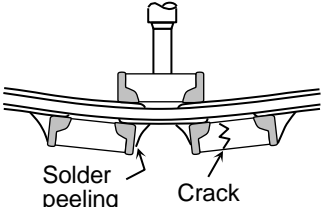
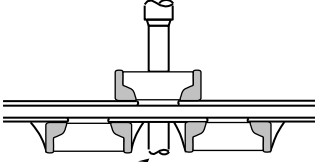
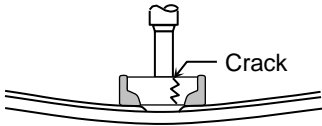
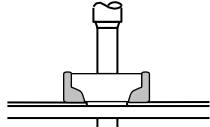
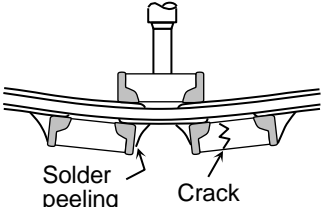
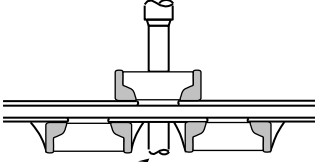
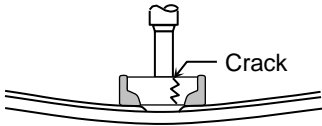
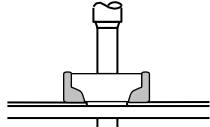
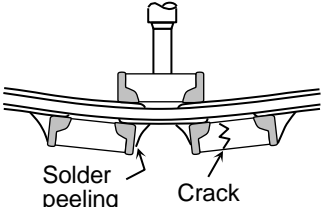
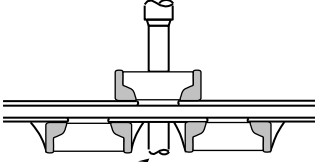
No.	Process	Condition									
4	Mounting	<p>4-1. Stress from mounting head If the mounting head is adjusted too low, it may induce excessive stress in the chip capacitors to result in cracking. Please take following precautions.</p> <ol style="list-style-type: none"> 1) Adjust the bottom dead center of the mounting head to reach on the P.C.board surface and not press it. 2) Adjust the mounting head pressure to be 1 to 3N of static weight. 3) To minimize the impact energy from mounting head, it is important to provide support from the bottom side of the P.C.board. See following examples. <table border="1" style="width: 100%; border-collapse: collapse;"> <thead> <tr> <th data-bbox="486 566 667 611"></th> <th data-bbox="667 566 1062 611">Not recommended</th> <th data-bbox="1062 566 1437 611">Recommended</th> </tr> </thead> <tbody> <tr> <td data-bbox="486 611 667 875">Single sided mounting</td> <td data-bbox="667 611 1062 875">  <p style="text-align: center;">Crack</p> </td> <td data-bbox="1062 611 1437 875">  <p style="text-align: center;">Support pin</p> <p style="text-align: center;">A support pin is not to be underneath the capacitor.</p> </td> </tr> <tr> <td data-bbox="486 875 667 1140">Double-sides mounting</td> <td data-bbox="667 875 1062 1140">  <p style="text-align: center;">Solder peeling Crack</p> </td> <td data-bbox="1062 875 1437 1140">  <p style="text-align: center;">Support pin</p> </td> </tr> </tbody> </table> <p>When the centering jaw is worn out, it may give mechanical impact on the capacitors to cause crack. Please control the close up dimension of the centering jaw and provide sufficient preventive maintenance and replacement of it.</p>		Not recommended	Recommended	Single sided mounting	 <p style="text-align: center;">Crack</p>	 <p style="text-align: center;">Support pin</p> <p style="text-align: center;">A support pin is not to be underneath the capacitor.</p>	Double-sides mounting	 <p style="text-align: center;">Solder peeling Crack</p>	 <p style="text-align: center;">Support pin</p>
	Not recommended	Recommended									
Single sided mounting	 <p style="text-align: center;">Crack</p>	 <p style="text-align: center;">Support pin</p> <p style="text-align: center;">A support pin is not to be underneath the capacitor.</p>									
Double-sides mounting	 <p style="text-align: center;">Solder peeling Crack</p>	 <p style="text-align: center;">Support pin</p>									

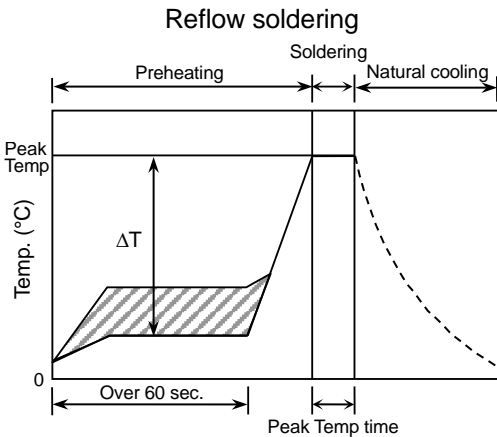
No.	Process	Condition														
5	Soldering	<p>5-1. Flux selection</p> <p>Flux can seriously affect the performance of capacitors. Confirm the following to select the appropriate flux.</p> <ol style="list-style-type: none"> 1) It is recommended to use a mildly activated rosin flux (less than 0.1wt% chlorine). Strong flux is not recommended. 2) Excessive flux must be avoided. Please provide proper amount of flux. 3) When water-soluble flux is used, enough washing is necessary. <p>5-2. Recommended Reflow soldering profile</p> <div style="text-align: center;">  <p style="text-align: center;">Reflow soldering</p> </div> <p>5-3. Recommended soldering peak temp and peak temp duration</p> <p>Pb free solder is recommended, but if Sn-37Pb must be used, refer to below.</p> <table border="1" style="margin-left: auto; margin-right: auto;"> <thead> <tr> <th rowspan="2" style="text-align: center;">Temp./Duration</th> <th colspan="2" style="text-align: center;">Reflow soldering</th> </tr> <tr> <th style="text-align: center;">Peak temp(°C)</th> <th style="text-align: center;">Duration(sec.)</th> </tr> </thead> <tbody> <tr> <td style="text-align: center;">Solder</td> <td></td> <td></td> </tr> <tr> <td style="text-align: center;">Lead Free Solder</td> <td style="text-align: center;">260 max.</td> <td style="text-align: center;">10 max.</td> </tr> <tr> <td style="text-align: center;">Sn-Pb Solder</td> <td style="text-align: center;">230 max.</td> <td style="text-align: center;">20 max.</td> </tr> </tbody> </table> <p>Recommended solder compositions Lead Free Solder : Sn-3.0Ag-0.5Cu</p>	Temp./Duration	Reflow soldering		Peak temp(°C)	Duration(sec.)	Solder			Lead Free Solder	260 max.	10 max.	Sn-Pb Solder	230 max.	20 max.
Temp./Duration	Reflow soldering															
	Peak temp(°C)	Duration(sec.)														
Solder																
Lead Free Solder	260 max.	10 max.														
Sn-Pb Solder	230 max.	20 max.														

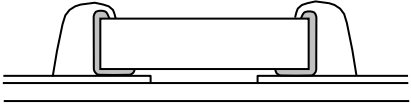
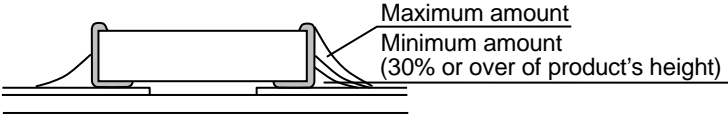
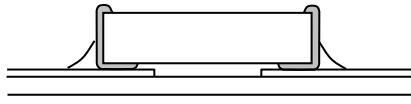
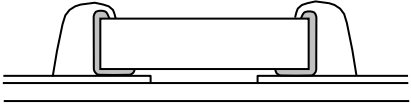
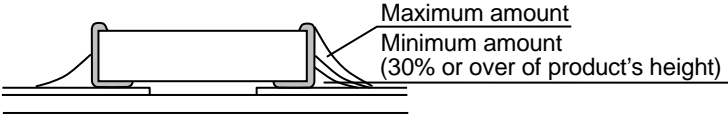
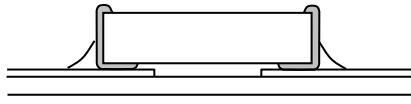
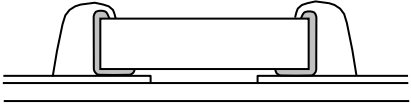
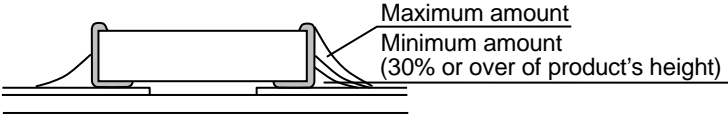
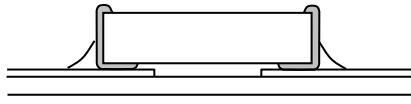
No.	Process	Condition																	
5	Soldering	<p>5-4. Avoiding thermal shock</p> <p>1) Preheating condition</p> <table border="1" data-bbox="539 241 1275 383"> <thead> <tr> <th data-bbox="539 241 767 293">Soldering</th> <th data-bbox="767 241 1007 293">Case size</th> <th data-bbox="1007 241 1275 293">Temp. (°C)</th> </tr> </thead> <tbody> <tr> <td data-bbox="539 293 767 338" rowspan="2">Reflow soldering</td> <td data-bbox="767 293 1007 338">CNA5(CC1206)</td> <td data-bbox="1007 293 1275 338">$\Delta T \leq 150$</td> </tr> <tr> <td data-bbox="767 338 1007 383">CNA6(CC1210)</td> <td data-bbox="1007 338 1275 383">$\Delta T \leq 130$</td> </tr> </tbody> </table> <p>2) Cooling condition Natural cooling using air is recommended. If the chips are dipped into a solvent for cleaning, the temperature difference (ΔT) must be less than 100°C.</p> <p>5-5. Amount of solder Excessive solder will induce higher tensile force in chip capacitors when temperature changes and it may result in chip cracking. In sufficient solder may detach the capacitors from the P.C.board.</p> <table border="1" data-bbox="483 685 1433 1149"> <tbody> <tr> <td data-bbox="483 685 683 835">Excessive solder</td> <td data-bbox="683 685 1098 835">  </td> <td data-bbox="1098 685 1433 835">Higher tensile force in chip capacitors to cause crack</td> </tr> <tr> <td data-bbox="483 835 683 992">Adequate</td> <td data-bbox="683 835 1098 992">  </td> <td data-bbox="1098 835 1433 992"></td> </tr> <tr> <td data-bbox="483 992 683 1149">Insufficient solder</td> <td data-bbox="683 992 1098 1149">  </td> <td data-bbox="1098 992 1433 1149">Low robustness may cause contact failure or chip capacitors come off the P.C.board.</td> </tr> </tbody> </table> <p>5-6. Sn-Zn solder Sn-Zn solder affects product reliability. Please contact TDK in advance when utilize Sn-Zn solder.</p> <p>5-7. Countermeasure for tombstone The misalignment between the mounted positions of the capacitors and the land patterns should be minimized. The tombstone phenomenon may occur especially the capacitors are mounted (in longitudinal direction) in the same direction of the reflow soldering. (Refer to JEITA RCR-2335C Annex A (Informative) Recommendations to prevent the tombstone phenomenon)</p>	Soldering	Case size	Temp. (°C)	Reflow soldering	CNA5(CC1206)	$\Delta T \leq 150$	CNA6(CC1210)	$\Delta T \leq 130$	Excessive solder		Higher tensile force in chip capacitors to cause crack	Adequate			Insufficient solder		Low robustness may cause contact failure or chip capacitors come off the P.C.board.
Soldering	Case size	Temp. (°C)																	
Reflow soldering	CNA5(CC1206)	$\Delta T \leq 150$																	
	CNA6(CC1210)	$\Delta T \leq 130$																	
Excessive solder		Higher tensile force in chip capacitors to cause crack																	
Adequate																			
Insufficient solder		Low robustness may cause contact failure or chip capacitors come off the P.C.board.																	

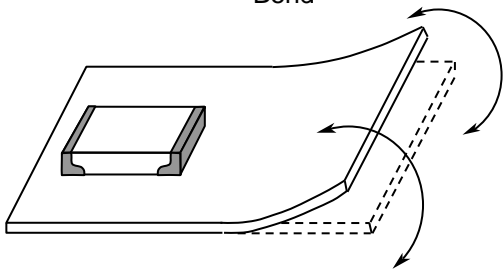
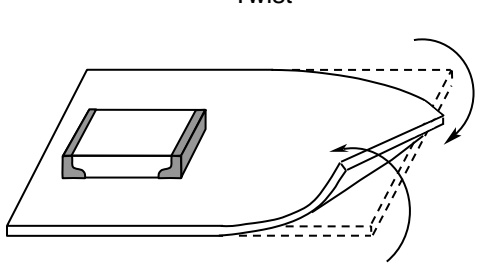
No.	Process	Condition
6	Cleaning	<p>1) If an unsuitable cleaning fluid is used, flux residue or some foreign articles may stick to chip capacitors surface to deteriorate especially the insulation resistance.</p> <p>2) If cleaning condition is not suitable, it may damage the chip capacitors.</p> <p>2)-1. Insufficient washing</p> <p>(1) Terminal electrodes may corrode by Halogen in the flux.</p> <p>(2) Halogen in the flux may adhere on the surface of capacitors, and lower the insulation resistance.</p> <p>(3) Water soluble flux has higher tendency to have above mentioned problems (1) and (2).</p> <p>2)-2. Excessive washing When ultrasonic cleaning is used, excessively high ultrasonic energy output can affect the connection between the ceramic chip capacitor's body and the terminal electrode. To avoid this, following is the recommended condition.</p> <p style="padding-left: 40px;">Power : 20W/ℓ max. Frequency : 40kHz max. Washing time : 5 minutes max.</p> <p>2)-3. If the cleaning fluid is contaminated, density of Halogen increases, and it may bring the same result as insufficient cleaning.</p>
7	Coating and molding of the P.C.board	<p>1) This product contains Ag (Silver) as part of the middle layer of termination. To avoid electromigration of Ag under high temperature and humidity, and failures caused by corrosive gas, chip capacitors on P.C boards should be protected by moisture proof-sealing.</p> <p>2) When the P.C.board is coated, please verify the quality influence on the product.</p> <p>3) Please verify carefully that there is no harmful decomposing or reaction gas emission during curing which may damage the chip capacitors.</p> <p>4) Please verify the curing temperature.</p>
8	Handling after chip mounted ⚠ Caution	<p>1) Please pay attention not to bend or distort the P.C.board after soldering in handling otherwise the chip capacitors may crack.</p> <div style="display: flex; justify-content: space-around; align-items: center;"> <div style="text-align: center;"> <p>Bend</p>  </div> <div style="text-align: center;"> <p>Twist</p>  </div> </div>

No.	Process	Condition															
8	Handling after chip mounted ⚠ Caution	<p>2) Printed circuit board cropping should not be carried out by hand, but by using the proper tooling. Printed circuit board cropping should be carried out using a board cropping jig as shown in the following figure or a board cropping apparatus to prevent inducing mechanical stress on the board.</p> <p>(1) Example of a board cropping jig Recommended example: The board should be pushed from the back side, close to the cropping jig so that the board is not bent and the stress applied to the capacitor is compressive. Unrecommended example: If the pushing point is far from the cropping jig and the pushing direction is from the front side of the board, large tensile stress is applied to the capacitor, which may cause cracks.</p> <div style="display: flex; justify-content: space-around;"> <div data-bbox="459 591 753 864"> <p>Outline of jig</p> </div> <div data-bbox="762 582 1442 842"> <table border="1"> <thead> <tr> <th data-bbox="769 591 1098 636">Recommended</th> <th data-bbox="1098 591 1436 636">Unrecommended</th> </tr> </thead> <tbody> <tr> <td data-bbox="769 636 1098 833"> </td> <td data-bbox="1098 636 1436 833"> </td> </tr> </tbody> </table> </div> </div> <p>(2) Example of a board cropping machine An outline of a printed circuit board cropping machine is shown below. The top and bottom blades are aligned with one another along the lines with the V-grooves on printed circuit board when cropping the board. Unrecommended example: Misalignment of blade position between top and bottom, right and left, or front and rear blades may cause a crack in the capacitor.</p> <div style="display: flex; justify-content: space-around;"> <div data-bbox="555 1155 963 1420"> <p>Outline of machine</p> </div> <div data-bbox="963 1155 1410 1397"> <p>Principle of operation</p> </div> </div> <div style="text-align: center; margin-top: 10px;"> <p>Cross-section diagram</p> </div> <table border="1" style="width: 100%; margin-top: 20px; border-collapse: collapse;"> <thead> <tr> <th data-bbox="644 1653 820 1733" rowspan="2">Recommended</th> <th colspan="3" data-bbox="820 1653 1353 1697">Unrecommended</th> </tr> <tr> <th data-bbox="820 1697 1002 1778">Top-bottom misalignment</th> <th data-bbox="1002 1697 1168 1778">Left-right misalignment</th> <th data-bbox="1168 1697 1353 1778">Front-rear misalignment</th> </tr> </thead> <tbody> <tr> <td data-bbox="644 1733 820 2078"> <p>Top blade</p> <p>Board</p> <p>Bottom blade</p> </td> <td data-bbox="820 1733 1002 2078"> <p>Top blade</p> <p>Bottom blade</p> </td> <td data-bbox="1002 1733 1168 2078"> <p>Top blade</p> <p>Bottom blade</p> </td> <td data-bbox="1168 1733 1353 2078"> <p>Top blade</p> <p>Bottom blade</p> </td> </tr> </tbody> </table>	Recommended	Unrecommended			Recommended	Unrecommended			Top-bottom misalignment	Left-right misalignment	Front-rear misalignment	<p>Top blade</p> <p>Board</p> <p>Bottom blade</p>	<p>Top blade</p> <p>Bottom blade</p>	<p>Top blade</p> <p>Bottom blade</p>	<p>Top blade</p> <p>Bottom blade</p>
Recommended	Unrecommended																
Recommended	Unrecommended																
	Top-bottom misalignment	Left-right misalignment	Front-rear misalignment														
<p>Top blade</p> <p>Board</p> <p>Bottom blade</p>	<p>Top blade</p> <p>Bottom blade</p>	<p>Top blade</p> <p>Bottom blade</p>	<p>Top blade</p> <p>Bottom blade</p>														

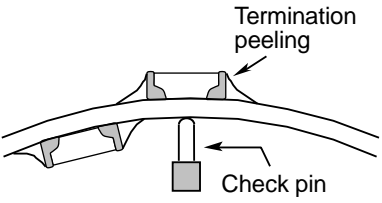
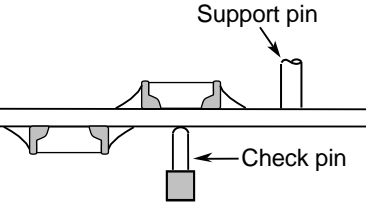
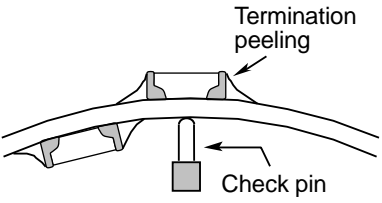
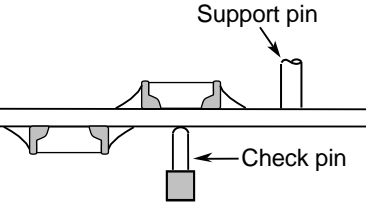
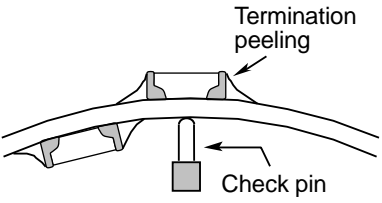
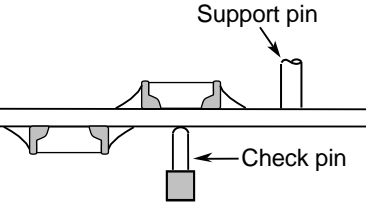
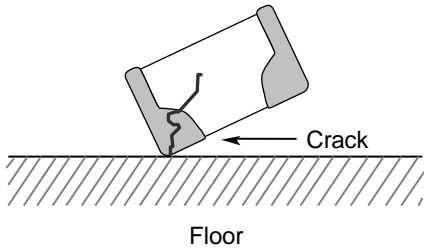
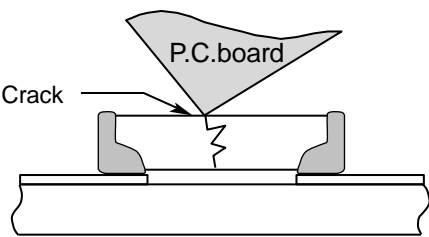
No.	Process	Condition						
8	Handling after chip mounted  Caution	<p data-bbox="475 185 1461 331">3) When functional check of the P.C.board is performed, check pin pressure tends to be adjusted higher for fear of loose contact. But if the pressure is excessive and bend the P.C.board, it may crack the chip capacitors or peel the terminations off. Please adjust the check pins not to bend the P.C.board.</p> <table border="1" data-bbox="475 383 1433 680"> <thead> <tr> <th data-bbox="475 383 616 443">Item</th> <th data-bbox="616 383 1034 443">Not recommended</th> <th data-bbox="1034 383 1433 443">Recommended</th> </tr> </thead> <tbody> <tr> <td data-bbox="475 443 616 680">Board bending</td> <td data-bbox="616 443 1034 680">  </td> <td data-bbox="1034 443 1433 680">  </td> </tr> </tbody> </table>	Item	Not recommended	Recommended	Board bending		
Item	Not recommended	Recommended						
Board bending								
9	Handling of loose chip capacitors	<p data-bbox="475 734 1461 824">1) If dropped the chip capacitors may crack. Once dropped do not use it. Especially, the large case sized chip capacitors are tendency to have cracks easily, so please handle with care.</p>  <p data-bbox="938 1048 995 1070">Floor</p> <p data-bbox="475 1081 1461 1149">2) Piling the P.C.board after mounting for storage or handling, the corner of the P.C. board may hit the chip capacitors of another board to cause crack.</p> 						
10	Capacitance aging	<p data-bbox="475 1440 1410 1541">The capacitors (Class 2) have aging in the capacitance. They may not be used in precision time constant circuit. In case of the time constant circuit, the evaluation should be done well.</p>						
11	Estimated life and estimated failure rate of capacitors	<p data-bbox="475 1563 1436 1731">As per the estimated life and the estimated failure rate depend on the temperature and the voltage. This can be calculated by the equation described in JEITA RCR-2335C Annex F(Informative) Calculation of the estimated lifetime and the estimated failure rate (Voltage acceleration coefficient : 3 multiplication rule, Temperature acceleration coefficient : 10°C rule)</p> <p data-bbox="475 1731 1430 1798">The failure rate can be decreased by reducing the temperature and the voltage but they will not be guaranteed.</p>						

No.	Process	Condition
12	Caution during operation of equipment	<p>1) A capacitor shall not be touched directly with bare hands during operation in order to avoid electric shock. Electric energy held by the capacitor may be discharged through the human body when touched with a bare hand. Even when the equipment is off, a capacitor may stay charged. The capacitor should be handled after being completely discharged using a resistor.</p> <p>2) The terminals of a capacitor shall not be short-circuited by any accidental contact with a conductive object. A capacitor shall not be exposed to a conductive liquid such as an acid or alkali solution. A conductive object or liquid, such as acid and alkali, between the terminals may lead to the breakdown of a capacitor due to short circuit</p> <p>3) Confirm that the environment to which the equipment will be exposed during transportation and operation meets the specified conditions. Do not to use the equipment in the following environments.</p> <p>(1) Environment where a capacitor is splattered with water or oil (2) Environment where a capacitor is exposed to direct sunlight (3) Environment where a capacitor is exposed to Ozone, ultraviolet rays or radiation (4) Environment where a capacitor exposed to corrosive gas(e.g. hydrogen sulfide, sulfur dioxide, chlorine. ammonia gas etc.) (5) Environment where a capacitor exposed to vibration or mechanical shock exceeding the specified limits. (6) Atmosphere change with causes condensation</p>
13	Others  Caution	<p>The product listed in this specification is intended for use in automotive applications under-normal operation and usage conditions.</p> <p>The product is not designed or warranted to meet the requirements of application listed below, whose performance and/or quality requires a more stringent level of safety or reliability, or whose failure, malfunction or defect could cause serious damage to society, person or property. Please understand that we are not responsible for any damage or liability caused by use of the products in any of the applications below or for any other use exceeding the range or conditions set forth in this specification sheet. If you intend to use the products in the applications listed below or if you have special requirements exceeding the range or conditions set forth in this specification, please contact us.</p> <p>(1) Aerospace/Aviation equipment (2) Transportation equipment (electric trains, ships etc.) (3) Medical equipment (Excepting Pharmaceutical Affairs Law classification Class1, 2) (4) Power-generation control equipment (5) Atomic energy-related equipment (6) Seabed equipment (7) Transportation control equipment (8) Public information-processing equipment (9) Military equipment (10) Electric heating apparatus, burning equipment (11) Disaster prevention/crime prevention equipment (12) Safety equipment (13) Other applications that are not considered general-purpose applications</p> <p>When designing your equipment even for general-purpose applications, you are kindly requested to take into consideration securing protection circuit/device or providing backup circuits in your equipment. In addition, although the product listed in this specification is intended for use in automotive applications as described above, it is not prohibited to use for general electronic equipment, whose performance and/or quality doesn't require a more stringent level of safety or reliability, or whose failure, malfunction or defect could not cause serious damage to society, person or property. Therefore, the description of this caution will be applied, when the product is used in general electronic equipment under a normal operation and usage conditions.</p>

13. TAPE PACKAGING SPECIFICATION

1. CONSTRUCTION AND DIMENSION OF TAPING

1-1. Dimensions of carrier tape

Dimensions of plastic tape shall be according to Appendix 3.

1-2. Bulk part and leader of taping

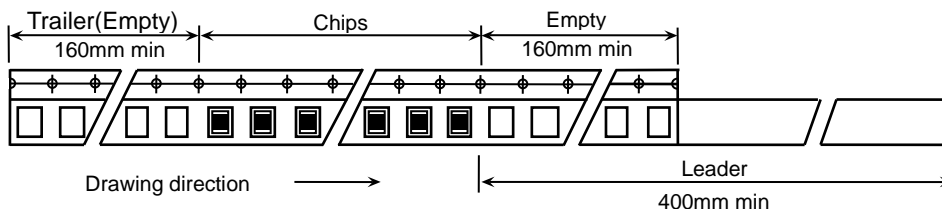

1-3. Dimensions of reel

Dimensions of $\varnothing 178$ reel shall be according to Appendix 4, 5.

Dimensions of $\varnothing 330$ reel shall be according to Appendix 6, 7.

1-4. Structure of taping

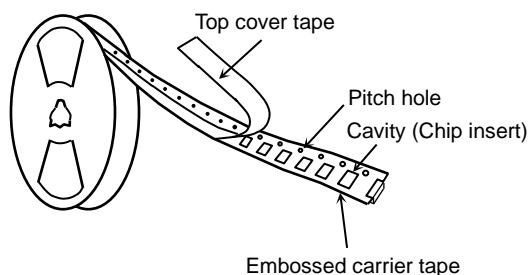

2. CHIP QUANTITY

Please refer to detail page on TDK web.

3. PERFORMANCE SPECIFICATIONS

3-1. Fixing peeling strength (top cover tape)

$$0.05\text{N} < \text{Peeling strength} < 0.7\text{N}$$

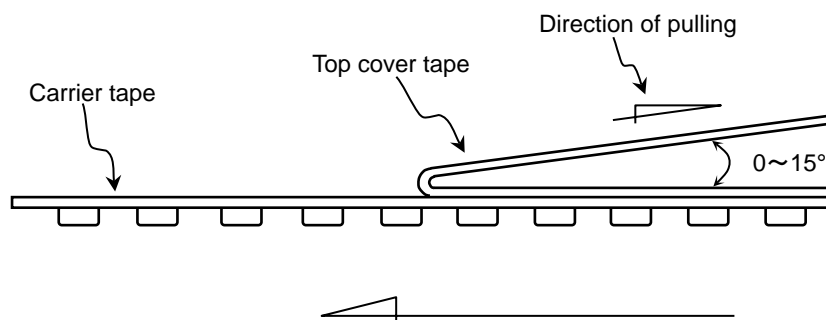

3-2. Carrier tape shall be flexible enough to be wound around a minimum radius of 30mm with components in tape.

3-3. The missing of components shall be less than 0.1%

3-4. Components shall not stick to fixing tape.

3-5. When removing the cover tape, there shall not be difficulties by unfitting clearance gap, burrs and crushes of cavities. Also the sprocket holes shall not be covered by absorbing dust into the suction nozzle.

Appendix 3

Plastic Tape

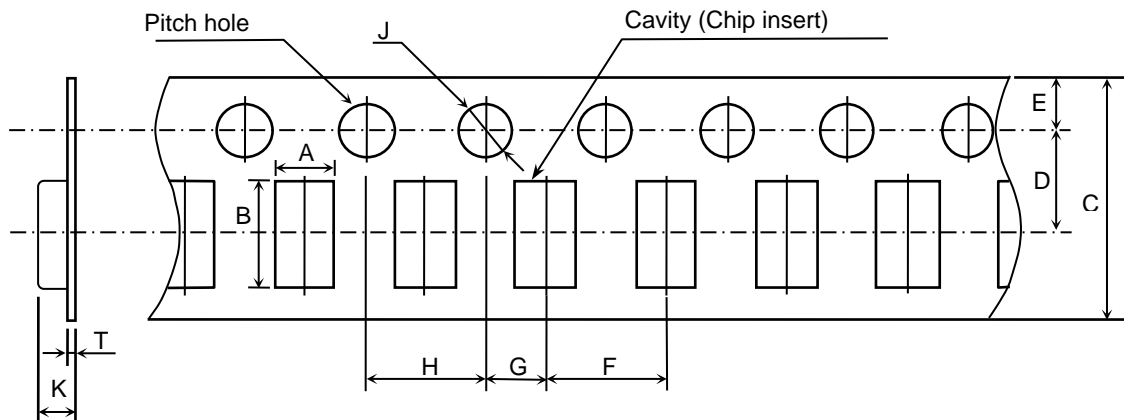

(Unit : mm)

Symbol Case size	A	B	C	D	E	F
CNA5 (CC1206)	(1.90)	(3.50)	8.00 ± 0.30	3.50 ± 0.05	1.75 ± 0.10	4.00 ± 0.10
CNA6 (CC1210)	(2.90)	(3.60)	12.0 ± 0.30	5.50 ± 0.05		
Symbol Case size	G	H	J	K	T	
CNA5 (CC1206)	2.00 ± 0.05	4.00 ± 0.10	∅ 1.50 ^{+0.10} ₀	2.50 max.	0.60 max.	
CNA6 (CC1210)				3.40 max.		

() Reference value.

Appendix 4

Dimensions of reel (Material : Polystyrene)
CNA5

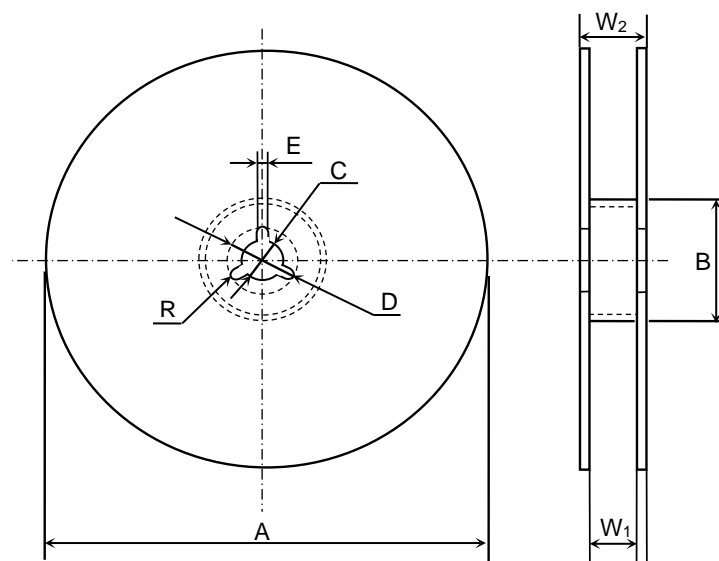

(Unit : mm)

Symbol	A	B	C	D	E	W ₁
Dimension	Ø178 ± 2.0	Ø60 ± 2.0	Ø13 ± 0.5	Ø21 ± 0.8	2.0 ± 0.5	9.0 ± 0.3
Symbol	W ₂	R				
Dimension	13.0 ± 1.4	1.0				

Appendix 5

Dimensions of reel (Material : Polystyrene)
CNA6

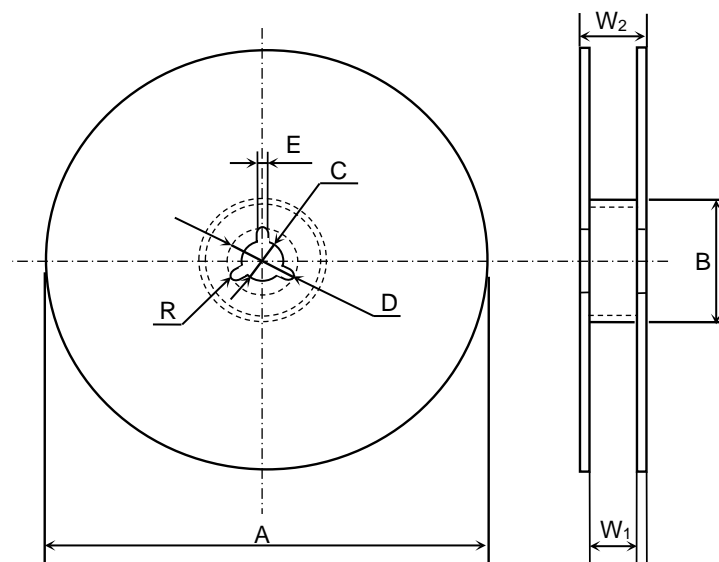

(Unit : mm)

Symbol	A	B	C	D	E	W ₁
Dimension	Ø178 ± 2.0	Ø60 ± 2.0	Ø13 ± 0.5	Ø21 ± 0.8	2.0 ± 0.5	13.0 ± 0.3
Symbol	W ₂	R				
Dimension	17.0 ± 1.4	1.0				

Appendix 6

Dimensions of reel (Material : Polystyrene)
CNA5

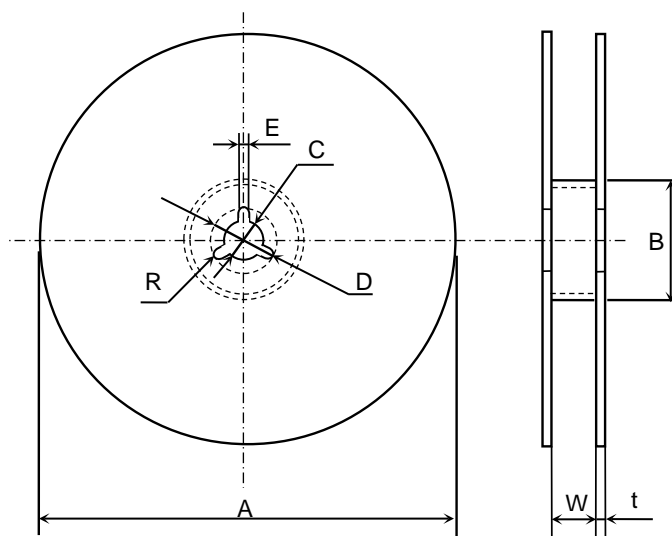

(Unit : mm)

Symbol	A	B	C	D	E	W
Dimension	Ø382 max. (Nominal Ø330)	Ø50 min.	Ø13 ± 0.5	Ø21 ± 0.8	2.0 ± 0.5	10.0 ± 1.5
Symbol	t	R				
Dimension	2.0 ± 0.5	1.0				

Appendix 7

Dimensions of reel (Material : Polystyrene)
CNA6

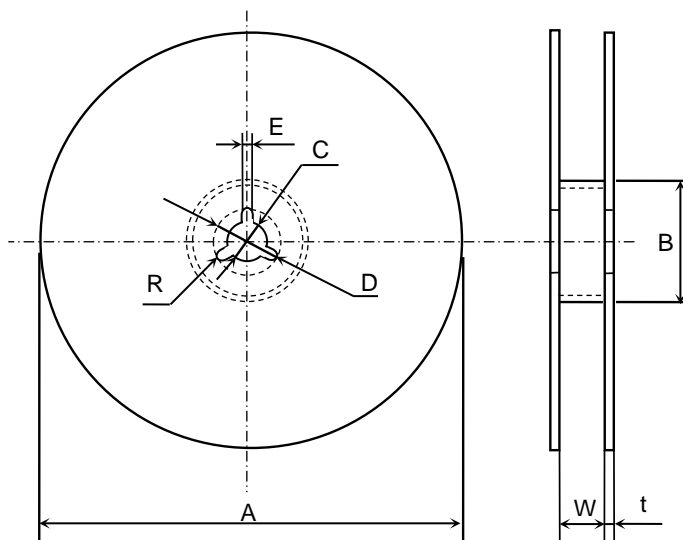

(Unit : mm)

Symbol	A	B	C	D	E	W
Dimension	Ø382 max. (Nominal Ø330)	Ø50 min.	Ø13 ± 0.5	Ø21 ± 0.8	2.0 ± 0.5	14.0 ± 1.5
Symbol	t	R				
Dimension	2.0 ± 0.5	1.0				