



American Opto Plus LED Corp.

L513LBGW-S

5mm Blue-Green LED Lamp, Tape and Reel

DESCRIPTION

- Round Type
- 5mm Diameter
- Lens Color: White Diffused
- With Flange
- Solder leads with standoffs

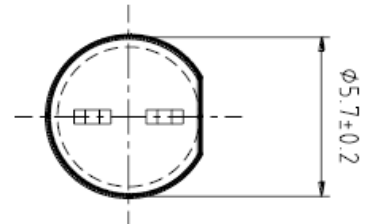

FEATURES

- Emitted Color: Blue-Green
- High Luminous Intensity
- Technology: InGaN
- Viewing Angle: 40°

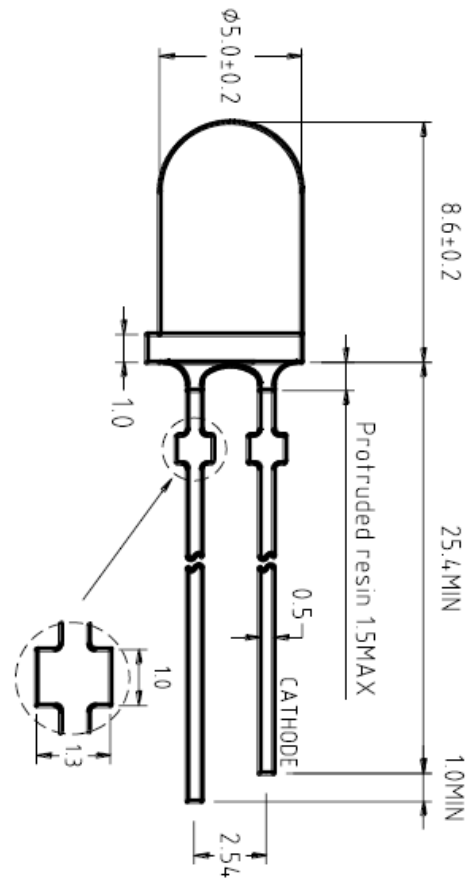

NOTE:

All dimensions are in millimeters tolerance is ± 0.25 mm unless otherwise noted

Part Number	Material	Lens Color	
		Emitted	Lens
L513LBGW-S	InGaN	Blue-Green	White Diffused



American Opto Plus LED Corp.

L513LBGW-S

5mm Blue-Green LED Lamp, Tape and Reel

ABSOLUTE MAXIMUM RATINGS

(Ta=25°C)

Parameter	Symbol	Ratings	Unit
DC Forward Current	I _F	30	mA
Peak Pulsed Forward Current	I _{FP}	100	mA
Power Dissipation	P _d	120	mW
Operating temperature range	T _{opr}	-20~+85	°C
Storage temperature range	T _{stg}	-30~+100	°C
Electrostatic Discharge	ESD	500	V

OPTICAL-ELECTRICAL CHARACTERISTICS

(Ta=25°C)

Parameter	Symbol	Test Condition	Min	Typ	Max	Unit
Reverse Current	I _R	V _R =5V	--	--	50	μA
Forward Voltage	V _F	I _F =20mA	--	3.5	4.2	V
Spectral halfwidth	Δλ		--	32	--	nm
Dominant Wavelength	λ _D		--	505	--	nm
Luminous Intensity	I _v		3400	5000	--	mcd
Viewing Angle	2θ ½		--	40	--	deg

***Note:**

1. The forward voltage data does not include ± 0.1V testing tolerance.
2. The luminous intensity data does not include ± 15% testing tolerance.



American Opto Plus LED Corp.

L513LBGW-S

5mm Blue-Green LED Lamp, Tape and Reel

BRIGHTNESS BIN CODE

Rank	Luminous Intensity (mcd) @ 20mA	
	Min	Max
A27	3400	4000
A28	4000	5000
A29	5000	6200
A30	6200	7700
A31	7700	9500

COLOR BIN CODE

Rank	Wavelength (nm) @ 20mA	
	Min	Max
1H	498	501
1I	501	504



American Opto Plus LED Corp.

L513LBGW-S

5mm Blue-Green LED Lamp, Tape and Reel

TYPICAL ELECTRICAL-OPTICAL CHARACTERISTIC CURVES

Fig.1 Forward current vs. Forward Voltage

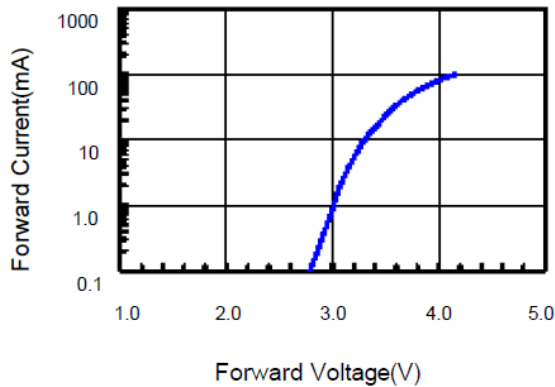

Fig.2 Relative Intensity vs. Forward Current

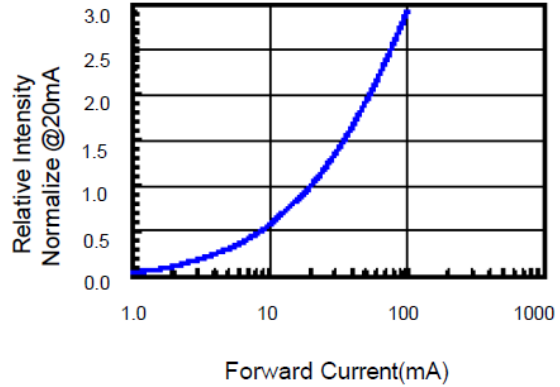

Fig.3 Forward Voltage vs. Temperature

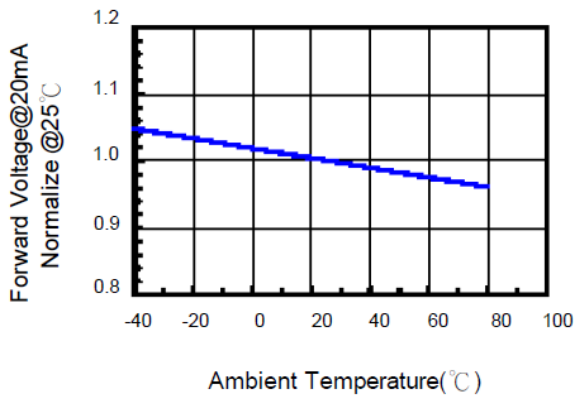

Fig.4 Relative Intensity vs. Temperature

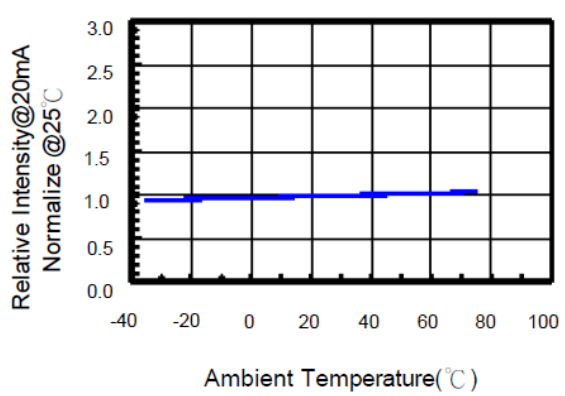
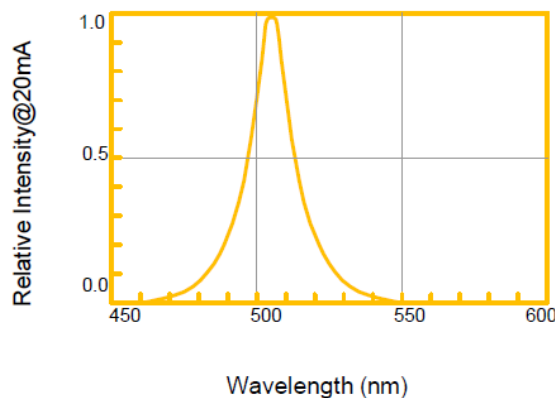
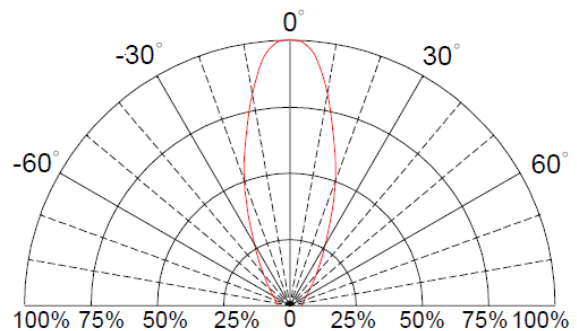

Fig.5 Relative Intensity vs. Wavelength



Directivity Radiation





American Opto Plus LED Corp.

L513LBGW-S

5mm Blue-Green LED Lamp, Tape and Reel

DIMENSIONS SYMBOL INFORMATION

Symbol Items	Option Code	Symbol	Specifications			
			Minimum		Maximum	
			mm	Inch	mm	Inch
Tape feed Hole Diameter	—	D	3.8	0.15	4.2	0.17
Component Lead Pitch	—	F	2.3	0.09	3	0.12
Front-To-Rear Deflection	—	ΔH	—	—	2	0.08
Feed Hole To Bottom Of Component	TRS-1	H1	17.5	0.69	18.5	0.73
	TRS-2		21.5	0.85	22.5	0.89
	TRS-3		25.5	1.0	26.5	1.04
	TRS-4		27.5	1.08	28.5	1.12
	TRS-5		22.5	0.89	23.5	0.93
	TRS-6		19.9	0.78	20.9	0.82
	TRS-7		24.0	0.94	25.0	0.98
	TRS-8		24.5	0.96	25.5	1.0
	TRS-9		19.0	0.75	20.0	0.79
	TRS-10		18.4	0.72	19.4	0.76
	TRS-11		21	0.83	22	0.87
	TRS-12		20.5	0.81	21.5	0.85
	TRS-13		18.0	0.71	19.0	0.75
	TRS-14		26.5	1.04	27.5	1.08
Remark: TRS=Tape AND Reel Straight Leads						
Feed Hole To Overall Component Height	—	H2	—	—	36	1.42
Lead Length After Component Height	—	L	WO		11	0.43
Feed Hole Pitch	—	P	12.4	0.49	13	0.51
Lead Location	—	P1	4.4	0.17	5.8	0.23
Center Of Component Location	—	P2	5.1	0.2	7.7	0.3
Overall Taped Package Thickness	—	T	—	—	1.42	0.06
Feed Hole Location	—	W0	8.5	0.33	9.75	0.38
Adhesive Tape Width	—	W1	14.5	0.57	15.5	0.61
Adhesive Tape Position	—	W2	0	0	4	0.16
Tape Width	—	W3	17.5	0.69	19	0.75
Reel Diameter	—	D	78.2	3.08	380	14.96
Core Diameter	—	D1	34.9	1.37	102	4.02
Hub Recess Inside Diameter	—	D2	28.6	1.13	88	3.46
Arbor Hole Diameter	—	D3	13.8	0.54	38.1	1.5
Overall Reel Thickness	—	T2	—	—	57.2	2.25
Inside Reel Flange Thickness	—	T1	30	1.18	50	1.97



American Opto Plus LED Corp.

L513LBGW-S

5mm Blue-Green LED Lamp, Tape and Reel

PACKAGE DIMENSIONS

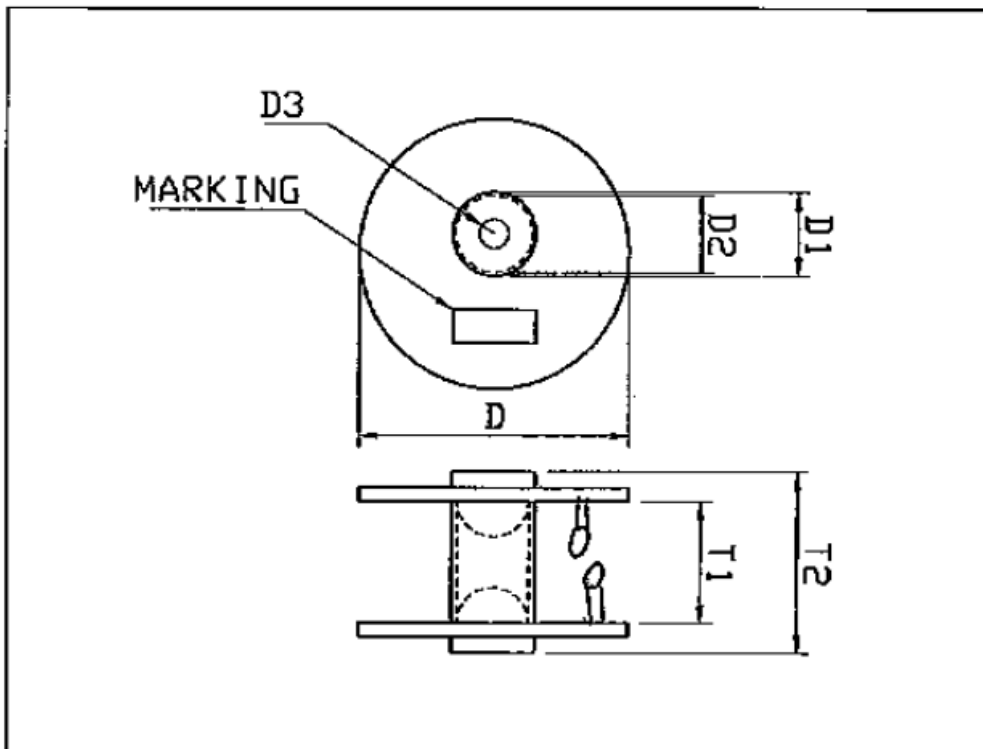
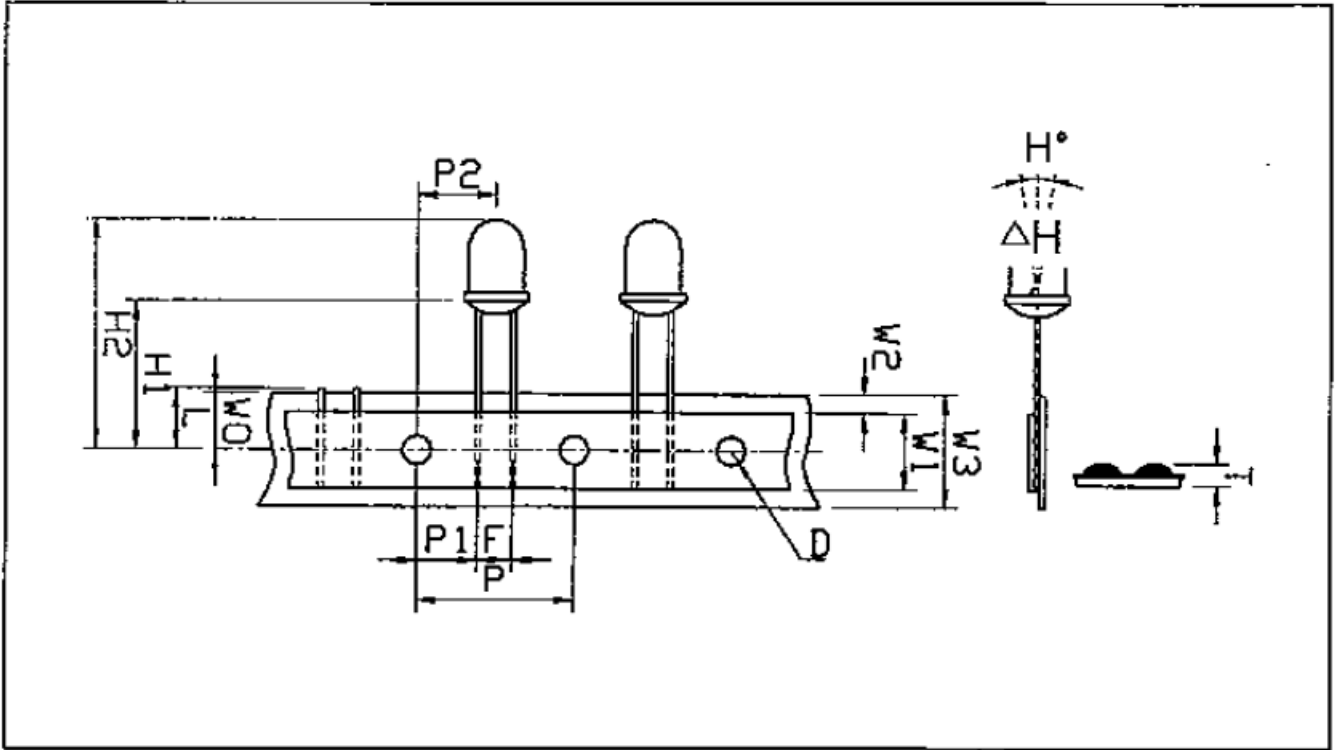

Version 1.2 Date: 11-14-2014 Specifications are subject to change without notice.

American Opto Plus LED Corp. 1206 E. Lexington Ave., Pomona CA 91766 Tel: 909-465-0080 Fax: 909-465-0130 www.aopled.com



American Opto Plus LED Corp.

L513LBGW-S

5mm Blue-Green LED Lamp, Tape and Reel

SOLDERING CONDITIONS – LAMP TYPE LED

1. Iron:

Soldering Iron: 30W Max
Temperature 350 °C Max
Soldering Time: 3 Seconds Max (One Time Only)
Distance: 2mm Min (From Solder Joint to Body)

2. Wave Soldering Profile:

Dip Soldering
Preheat: 120°C Max
Preheat Time: 60 Seconds Max
Ramp-Up
2°C/Sec (Max)
Ramp-Down: -5°C/Sec (Max)
Solder Bath: 260°C Max
Dipping Time: 3 Seconds Max
Distance: 2mm Min (From Solder Joint to Body)

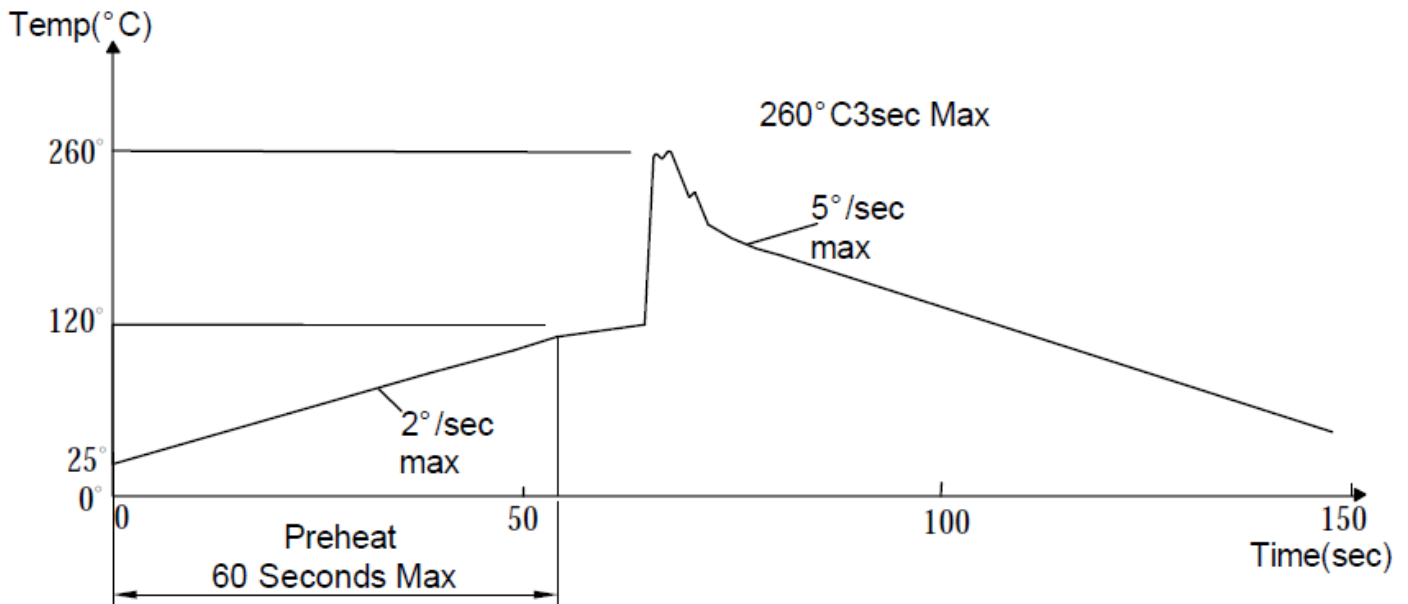

Note:

1. Wave solder should not be made more than one time.
2. Only select one of the soldering conditions above.



American Opto Plus LED Corp.

L513LBGW-S

5mm Blue-Green LED Lamp, Tape and Reel

RELIABILITY TEST

Test Item	Test Condition	Description	Reference Standard
Operating Life Test	1. Under Room Temperature 2. If=20mA 3. t=1000 hrs (-24hrs, +72hrs)	This test is conducted for the purpose of determining the resistance of a part in electrical and thermal stressed.	MIL-STD-750: 1026 MIL-STD-883: 1005 JIS C 7021: B-1
High Temperature Storage Test	1. Ta=105°C±5°C 2. t=1000 hrs (-24hrs, +72hrs)	The purpose of this is the resistance of the device which is laid under condition of high temperature for hours.	MIL-STD-883:1008 JIS C 7021: B-10
Low Temperature Storage Test	1. Ta=-40°C±5°C 2. t=1000 hrs (-24hrs, +72hrs)	The purpose of this is the resistance of the device which is laid under condition of low temperature for hours.	JIS C 7021: B-12
High Temperature High Humidity Test	1. Ta=65°C±5°C 2. RH=90%~95% 3. t=240hrs±2hrs	The purpose of this test is the resistance of the device under tropical for hours.	MIL-STD-202:103B JIS C 7021: B-11
Thermal Shock Test	1. Ta=105°C±5°C & -40°C±5°C (10min) (10min) 2. total 10 cycles	The purpose of this is the resistance of the device to sudden extreme changes in high and low temperature.	MIL-STD-202: 107D MIL-STD-750: 1051 MIL-STD-883: 1011
Solder Resistance Test	1. T.Sol=260°C±5°C 2. Dwell time= 10±1sec.	This test intended to determine the thermal characteristic resistance of the device to sudden exposures at extreme changes in temperature when soldering the lead wire.	MIL-STD-202: 210A MIL-STD-750: 2031 JIS C 7021: A-1
Solderability Test	1. T.Sol=245°C±5°C 2. Dwell time=5±1sec	This test intended to see soldering well performed or not.	MIL-STD-202: 208D MIL-STD-750: 2026 MIL-STD-883: 2003 JIS C 7021: A-2