

T-51-10-16

BURR-BROWN®  
**BB**

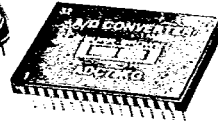
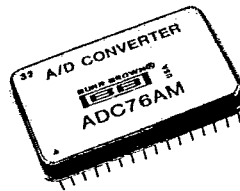

# ADC76

*NEW  
LOWER PRICES!*

## 16-Bit ANALOG-TO-DIGITAL CONVERTER

### FEATURES

- 16-BIT RESOLUTION
- LINEARITY ERROR  $\pm 0.003\%$  MAX (KM, BM)
- NO MISSING CODES GUARANTEED FROM  $0^{\circ}\text{C}$  TO  $+70^{\circ}\text{C}$
- $15\mu\text{s}$  CONVERSION TIME (15-BIT)
- SERIAL AND PARALLEL OUTPUTS
- COMPACT DESIGN  
32-pin Ceramic or Hermetic Metal Package
- LOW COST

### DESCRIPTION

The ADC76 is a low cost, high quality, 16-bit successive approximation analog-to-digital converter. The ADC76 uses state-of-the-art IC and laser-trimmed thin-film components and is packaged in a convenient 32-pin dual-in-line package. The converter is complete with internal reference, short cycling capabilities, serial output, and thin-film scaling resistors, which allow selection of analog input ranges of  $\pm 2.5\text{V}$ ,  $\pm 5\text{V}$ ,  $\pm 10\text{V}$ ,  $0$  to  $+5\text{V}$ ,  $0$  to  $+10\text{V}$  and  $0$  to  $+20\text{V}$ .

It is specified for operation over two temperature ranges:  $0^{\circ}\text{C}$  to  $+70^{\circ}\text{C}$  (J, K) and  $-25^{\circ}\text{C}$  to  $+85^{\circ}\text{C}$  (A, B).

Data is available in parallel and serial form with corresponding clock and status output. All digital inputs and outputs are TTL-compatible.

Power supply voltages are  $\pm 15\text{VDC}$   $+5\text{VDC}$ .

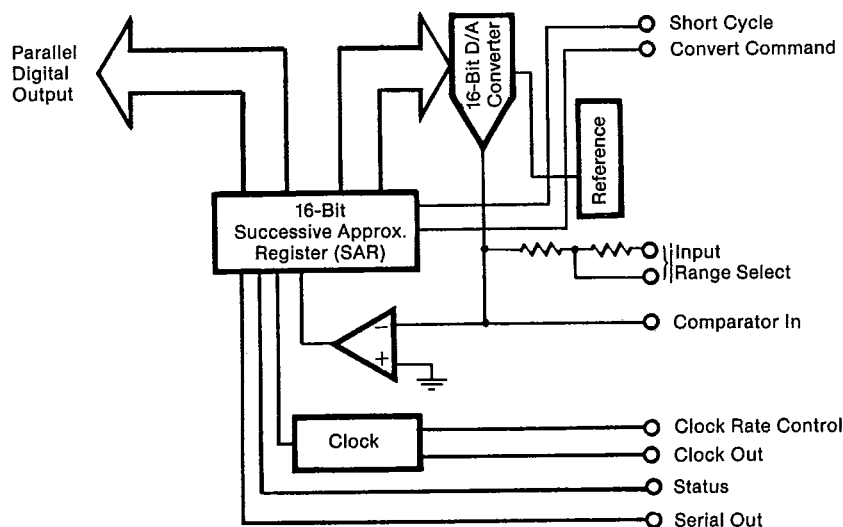

# SPECIFICATIONS

## ELECTRICAL

At +25°C and rated power supplies unless otherwise noted.

MODEL	ADC76J, K			ADC76A, B			UNITS	
	MIN	TYP	MAX	MIN	TYP	MAX		
<b>RESOLUTION</b>			16			*	Bits	
<b>ANALOG INPUTS</b>								
Voltage Ranges: Bipolar Unipolar		±2.5, ±5, ±10 0 to +5, 0 to +10, 0 to +20			*	*	V V	
Impedance (Direct Input) 0 to +5V, ±2.5V 0 to +10V, ±5.0V 0 to +20V, ±10V		2.5 5 10			*	*	kΩ kΩ kΩ	
<b>DIGITAL INPUTS<sup>(1)</sup></b>								
Convert Command Logic Loading	Positive pulse 50ns wide (min) trailing edge ("1" to "0" initiates conversion) 1						*	TTL Load
<b>TRANSFER CHARACTERISTICS</b>								
<b>ACCURACY</b> Gain Error <sup>(2)</sup> Offset Error: Unipolar <sup>(2)</sup> Bipolar <sup>(2)</sup> Linearity Error: K, B J, A Inherent Quantization Error Differential Linearity Error Noise (3σ, p-p)		±0.1 ±0.05 ±0.1 ±1/2 ±0.003 ±0.003	±0.2 ±0.1 ±0.2 ±0.003 ±0.006		*	*	% % of FSR <sup>(3)</sup> % of FSR % of FSR % of FSR LSB % of FSR % of FSR	
<b>POWER SUPPLY SENSITIVITY</b> ±15VDC +5VDC		0.003 0.001			*	*	% of FSR/%V <sub>s</sub> % of FSR/%V <sub>s</sub>	
<b>CONVERSION TIME<sup>(4)</sup></b> 14 Bits 15 Bits 16 Bits			15 16 17			*	μs μs μs	
<b>WARM-UP TIME</b>	5			*			min	
<b>DRIFT</b> Gain Offset: Unipolar Bipolar Linearity No Missing Codes Temp Range J, A (13-bit) K, B (14-bit)		±2 ±2	±15 ±4 ±10 ±3 +70 +70		*	*	ppm/°C ppm of FSR/°C ppm of FSR/°C ppm of FSR/°C °C °C	
<b>OUTPUT</b>								
<b>DIGITAL DATA</b> (All codes complementary) Parallel Output Codes <sup>(5)</sup> : Unipolar Bipolar Output Drive Serial Data Code (NRZ) Output Drive Status Status Output Drive Internal Clock: Clock Output Drive Frequency <sup>(7)</sup>		CSB COB, CTC <sup>(6)</sup> CSB, COB Logic "1" during conversion	2 2 2		*	*	TTL Loads TTL Loads TTL Loads TTL Loads kHz	
<b>POWER SUPPLY REQUIREMENTS</b> Power Consumption Rated Voltage: Analog Digital Supply Drain: +15VDC -15VDC +5VDC	±14.5 +4.75	0.525 ±15 +5 +14 -17 +10	±15.5 +5.25	*	*	*	W VDC VDC mA mA mA	
<b>TEMPERATURE RANGE</b> Specification Storage	0 -55		+70 +125	-25 *		+85 *	°C °C	

\*Specification same as ADC76J, K.

NOTES: (1) DTL/TTL compatible, i.e., Logic "0" = 0.8V, max, Logic "1" = 2.0V, min for inputs. For digital outputs Logic "0" = 0.4V, max, Logic "1" = 2.4V, min. (2) Adjustment to zero. See "Optional External Gain and Offset Adjustment" section. (3) FSR means Full Scale Range. For example, unit connected for ±10V range has 20V FSR. (4) Conversion time may be shortened with "Short Cycle" set for lower resolution and with use of Clock Rate

Control. See "Optional Conversion Time Adjustment" section. The Clock Rate Control (pin 23) should be connected to Digital Common for specified conversion time. Short Cycle (pin 32) should be left open for 16-bit resolution or connected to the n + 1 digital output for n-bit resolution. For example, connect Short Cycle to Bit 15 (pin 15) for 14-bit resolution. For resolutions less than 16 bits, pin 32 should also be tied to +5V through a 2kΩ resistor. (5) See Table I. CSB—Complementary Straight Binary, COB—Complementary Offset Binary, CTC—Complementary Two's Complement. (6) CTC coding obtained by inverting MSB (pin 1). (7) Adjustable with Clock Rate Control from approximately 933kHz to 1.4MHz. See Figures 12 and 13 and Table III.

The information provided herein is believed to be reliable; however, BURR-BROWN assumes no responsibility for inaccuracies or omissions. BURR-BROWN assumes no responsibility for the use of this information, and all use of such information shall be entirely at the user's own risk. Prices and specifications are subject to change without notice. No patent rights or licenses to any of the circuits described herein are implied or granted to any third party. BURR-BROWN does not authorize or warrant any BURR-BROWN product for use in life support devices and/or systems.

**MECHANICAL**

**G Package-32-Pin Ceramic**

DIM	INCHES		MILLIMETERS	
	MIN	MAX	MIN	MAX
A	1.678	1.712	42.62	43.48
B	1.079	1.101	27.41	27.97
C	.180	.210	4.57	5.33
D	.016	.020	.41	.51
F	.045	.055	1.14	1.40
G	.100 BASIC		2.54 BASIC	
H	.089	.106	2.26	2.69
J	.009	.012	.23	.30
K	.200	.210	5.08	5.33
L	.900 BASIC		22.86 BASIC	
N	.015	.035	.38	.89

NOTE: Leads in true position within 0.010" (0.25mm) R at MMC at seating plane.

Pin numbers shown for reference only. Numbers may not be marked on package.

CASE: Ceramic  
 MATING CONNECTOR: 2302MC  
 WEIGHT: 13 grams (0.46 oz.)  
 HERMETICITY: Conforms to Method 1014, Condition C, Step 1 (fluorocarbon) of MIL-STD-883 (gross leak).

**M Package-32-Pin Hermetic Metal DIP**

NOTE: Leads in true position within .010" (.25mm) R at MMC at seating plane.

DIM	INCHES		MILLIMETERS	
	MIN	MAX	MIN	MAX
A	1.720	1.760	43.69	44.70
B	1.120	1.160	28.45	29.46
C	0.170	0.250	4.32	6.35
D	0.16	0.021	0.41	0.53
G	.100 BASIC		2.54 BASIC	
H	0.100	0.140	2.54	3.56
K	0.150	0.300	3.81	7.62
L	.900 BASIC		22.86 BASIC	
R	0.100	0.140	2.54	3.56

Pin numbers shown for reference only. Numbers may not be marked on package.

**ABSOLUTE MAXIMUM SPECIFICATIONS**

+V <sub>cc</sub> to Common	0V to +16.5V
-V <sub>cc</sub> to Common	0V to -16.5V
+V <sub>DD</sub> to Common	0V to +7V
Analog Common to Digital Common	±0.5V
Logic Inputs to Common	0V to V <sub>DD</sub>
Maximum Power Dissipation	1000mW
Lead Temperature (10s)	300°C

CONNECTION DIAGRAM

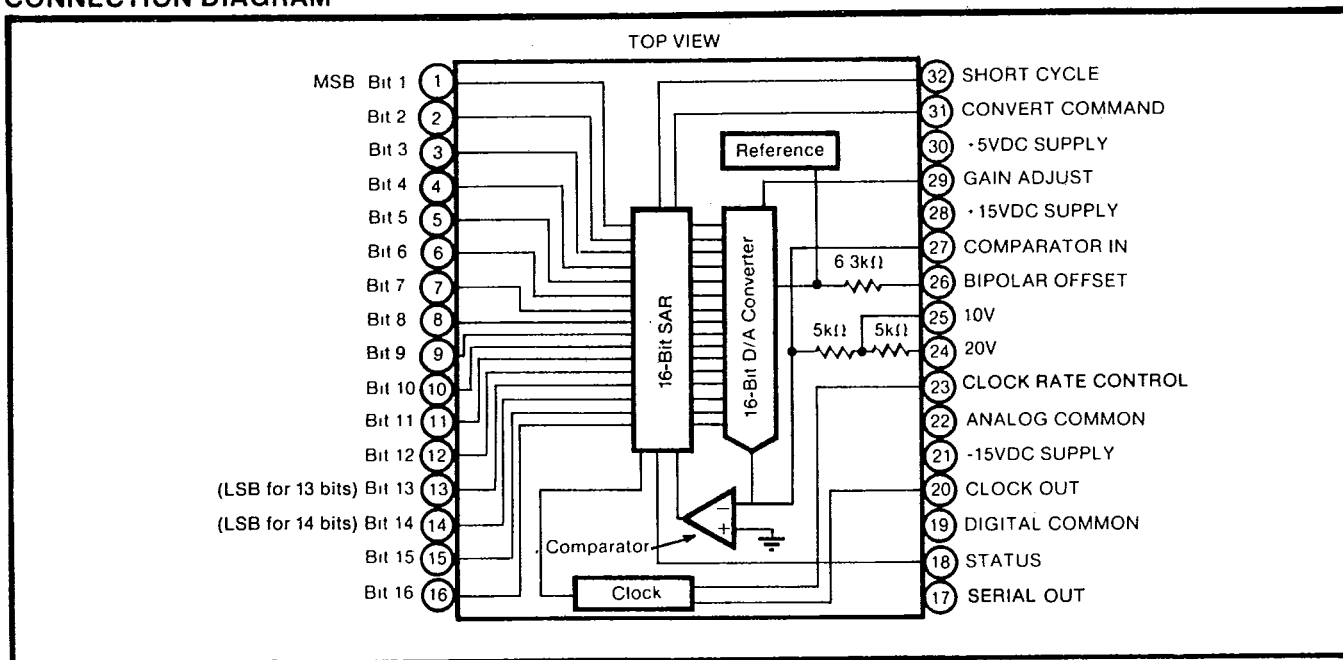

ORDERING INFORMATION

Model	1-49	50-99	100-249
ADC76JG (13-bit)	\$142.50	\$130.40	\$100.00
ADC76JM (13-bit)	219.30	178.50	153.00
ADC76KG (14-bit)	163.60	147.60	120.30
ADC76KM (14-bit)	265.20	224.40	191.66
ADC76AM (13-bit)	287.03	229.19	197.06
ADC76BM (14-bit)	337.37	269.89	231.34

TYPICAL PERFORMANCE CURVES

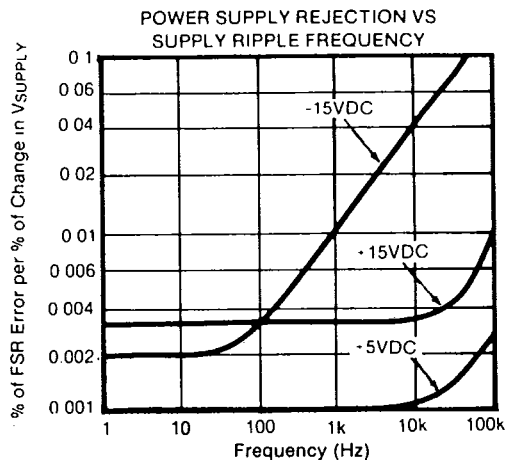
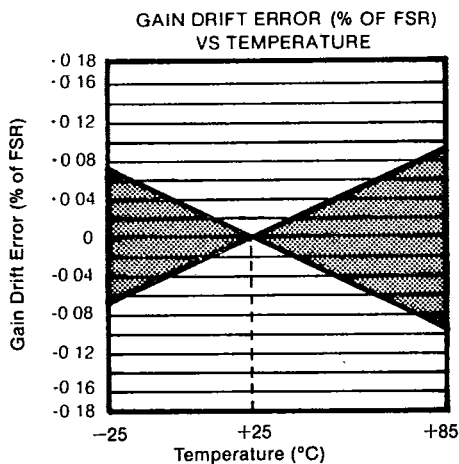

THEORY OF OPERATION

The accuracy of a successive approximation A/D converter is described by the transfer function shown in Figure 1. All successive approximation A/D converters have an inherent Quantization Error of  $\pm 1/2\text{LSB}$ . The remaining errors in the A/D converter are combinations of analog errors due to the linear circuitry, matching and tracking properties of the ladder and scaling networks, power supply rejection, and reference errors. In summary, these errors consist of initial errors including Gain,

Offset, Linearity, Differential Linearity, and Power Supply Sensitivity. Initial Gain and Offset errors may be adjusted to zero. Gain drift over temperature rotates the line (Figure 1) about the zero or minus full scale point (all bits Off) and Offset drift shifts the line left or right over the operating temperature range. Linearity error is unadjustable and is the most meaningful indicator of A/D converter accuracy. Linearity error is the deviation of an actual bit transition from the ideal transition value at any level over the range of the A/D converter. A Differential Linearity error of  $\pm 1/2\text{LSB}$  means that the

width of each bit step over the range of the A/D converter is 1LSB,  $\pm 1/2$ LSB.

The ADC76 is also Monotonic, assuring that the output digital code either increases or remains the same for increasing analog input signals. Burr-Brown also guarantees that this converter will have no missing codes over a specified temperature range when short cycled for 14-bit operation.

**TIMING CONSIDERATIONS**

The timing diagram in Figure 2 assumes an analog input such that the positive true digital word 1001 1000 1001 0110 exists. The output will be complementary as shown in Figure 2 (0110 0111 0110 1001 is the digital output). Figures 3 and 4 are timing diagrams showing the relationship of serial data to clock and valid data to status.

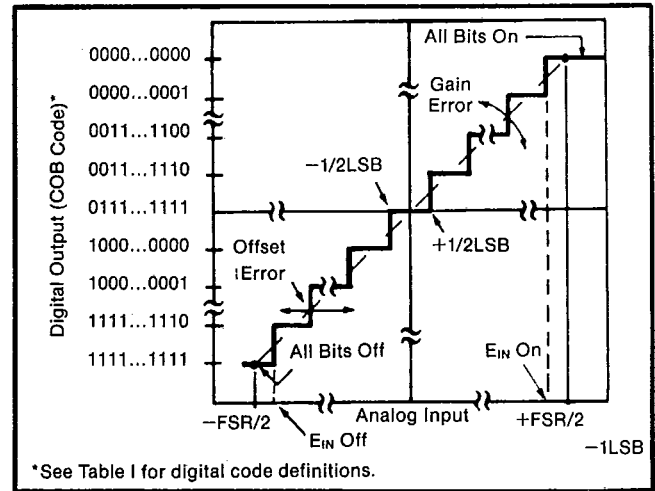

FIGURE 1. Input vs Output for an Ideal Bipolar A/D Converter.

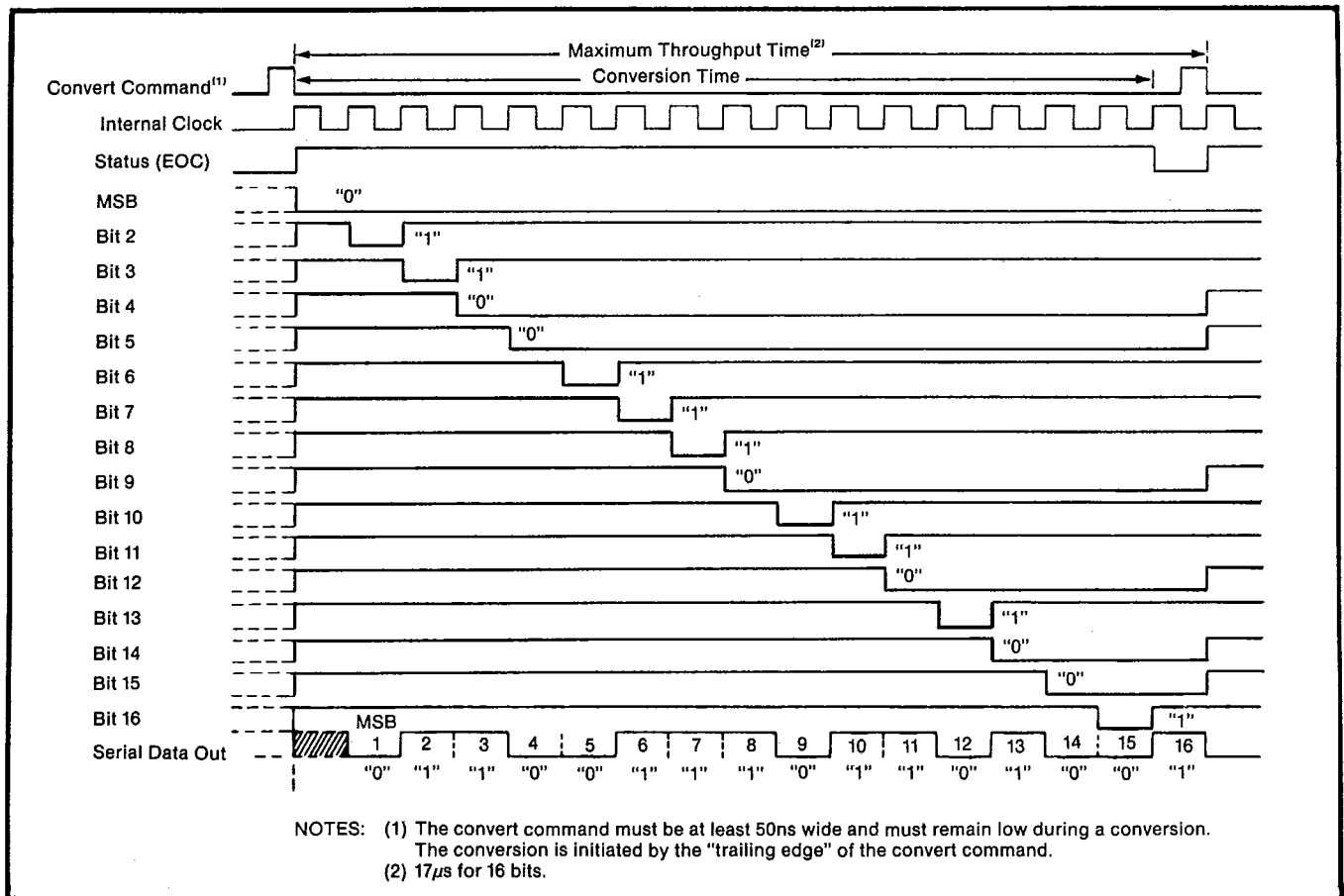

FIGURE 2. ADC76 Timing Diagram.

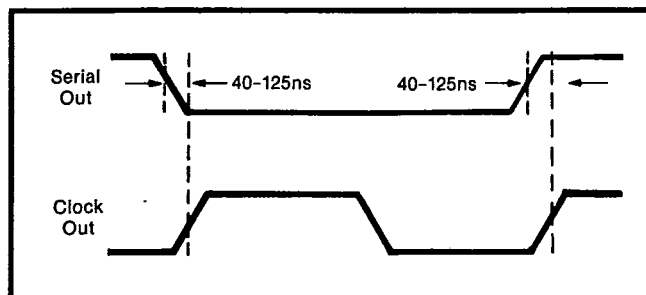

FIGURE 3. Timing Relationship of Serial Data to Clock.

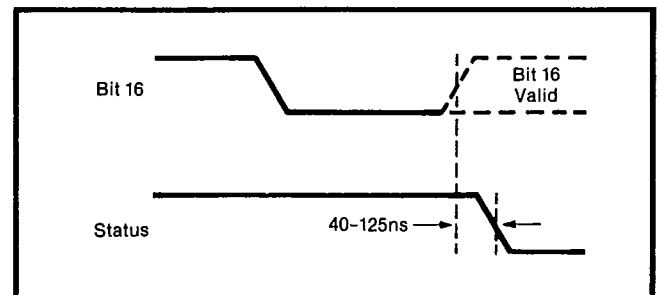

FIGURE 4. Timing Relationship of Valid Data to Status.

**DIGITAL CODES**

**Parallel Data**

Two binary codes are available on the ADC76 parallel output: they are complementary (logic "0" is true) straight binary (CSB) for unipolar input signal ranges, and complementary offset binary (COB) for bipolar input signal ranges. Complementary two's complement (CTC) may be obtained by inverting MSB (pin 1).

Table I shows the LSB, transition values, and code definitions for each possible analog input signal range for 12-, 13- and 14-bit resolutions. Figure 5 shows the connections for 14-bit resolution, parallel data output, with  $\pm 10V$  input.

**Serial Data**

Two straight binary (complementary) codes are available on the serial output line; they are CSB and COB. The serial data is available only during conversion and appears with MSB occurring first. The serial data is synchronous with the internal clock as shown in the timing diagrams of Figures 2 and 3. The LSB and transition values shown in Table I also apply to the serial data output except for the CTC code.

TABLE I. Input Voltages, Transition Values, LSB Values, and Code Definitions.

Binary (BIN) Output	INPUT VOLTAGE RANGE AND LSB VALUES						
	Defined As:	$\pm 10V$	$\pm 5V$	$\pm 2.5V$	0 to +10V	0 to +5V	0 to +20V
Code Designation		COB <sup>(1)</sup> or CTC <sup>(2)</sup>	COB <sup>(1)</sup> or CTC <sup>(2)</sup>	COB <sup>(1)</sup> or CTC <sup>(2)</sup>	CSB <sup>(3)</sup>	CSB <sup>(3)</sup>	CSB <sup>(3)</sup>
One Least Significant Bit (LSB)	$\frac{FSR}{2^n}$ n = 12 n = 13 n = 14	$\frac{20V}{2^n}$ 4.88mV 2.44mV 1.22mV	$\frac{10V}{2^n}$ 2.44mV 1.22mV 610 $\mu$ V	$\frac{5V}{2^n}$ 1.22mV 610 $\mu$ V 305 $\mu$ V	$\frac{10V}{2^n}$ 2.44mV 1.22mV 610 $\mu$ V	$\frac{5V}{2^n}$ 1.22mV 610 $\mu$ V 305 $\mu$ V	$\frac{20V}{2^n}$ 4.88mV 2.44mV 1.22mV
Transition Values MSB LSB 000...000 <sup>(4)</sup> 011...111 111...110	+Full Scale Mid Scale -Full Scale	+10V -3/2LSB 0 -10V +1/2LSB	+5V -3/2LSB 0 -5V +1/2LSB	+2.5V -3/2LSB 0 -2.5V +1/2LSB	+10V -3/2LSB +5V 0 + 1/2LSB	+5V -3/2LSB +2.5V 0 + 1/2LSB	+20V -3/2LSB +10V 0 + 1/2LSB

NOTES: (1) COB = Complementary Offset Binary.  
 (2) Complementary Two's Complement—obtained by inverting the most significant bit, MSB (pin 1).  
 (3) CSB = Complementary Straight Binary.  
 (4) Voltages given are the nominal value for transition to the code specified.

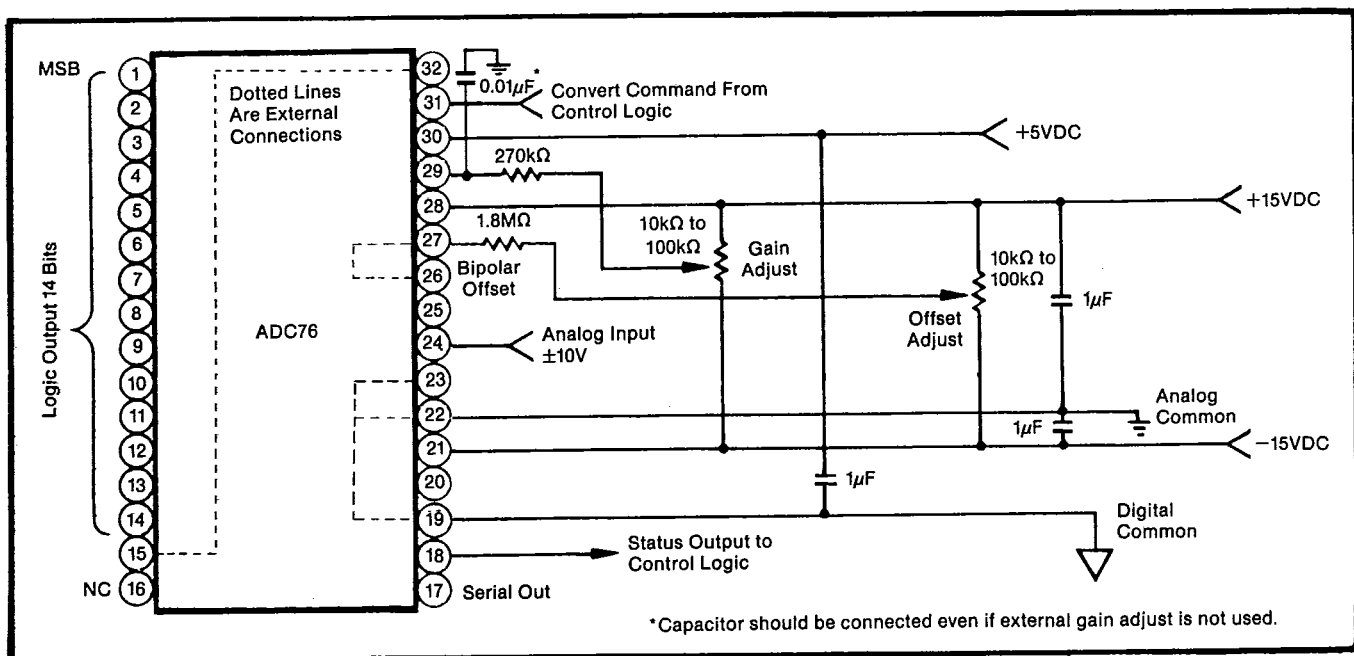

FIGURE 5. ADC76 Connections for:  $\pm 10V$  Analog Input, 14-Bit Resolution (Short-Cycled), Parallel Data Output.

## DISCUSSION OF SPECIFICATIONS

The ADC76 is specified to meet critical performance criteria for a wide variety of applications. The most critical specifications for an A/D converter are linearity, drift, gain and offset errors, and conversion speed effects on accuracy. This ADC is factory-trimmed and tested for all critical key specifications.

### GAIN AND OFFSET ERROR

Initial Gain and Offset errors are factory-trimmed to typically  $\pm 0.1\%$  of FSR ( $\pm 0.05\%$  for unipolar offset) at 25°C. These errors may be trimmed to zero by connecting external trim potentiometers as shown in Figures 10 and 11.

### POWER SUPPLY SENSITIVITY

Changes in the DC power supply voltages will affect accuracy. The ADC76 power supply sensitivity is specified at  $\pm 0.003\%$  of FSR/ $\%V_s$  for the  $\pm 15V$  supplies and  $\pm 0.0015\%$  of FSR/ $\%V_s$  for the +5V supply. Normally, regulated power supplies with 1% or less ripple are recommended for use with this ADC. See Layout Precautions, Power Supply Decoupling, and Figure 7.

### LINEARITY ERROR

Linearity error is not adjustable and is the most meaningful indicator of A/D converter accuracy. Linearity is the deviation of an actual bit transition from the ideal transition value at any level over the range of the A/D converter.

### DIFFERENTIAL LINEARITY ERROR

Differential linearity describes the step size between transition values. A differential linearity error of  $\pm 0.003\%$  of FSR indicates that the size of any step may not vary from the ideal step size by more than 0.003% of Full Scale Range.

### ACCURACY VERSUS SPEED

In successive approximation A/D converters, the conversion speed affects linearity and differential linearity errors. Conversion speed and its effect on linearity and differential linearity errors for the ADC76 are shown in Figure 6.

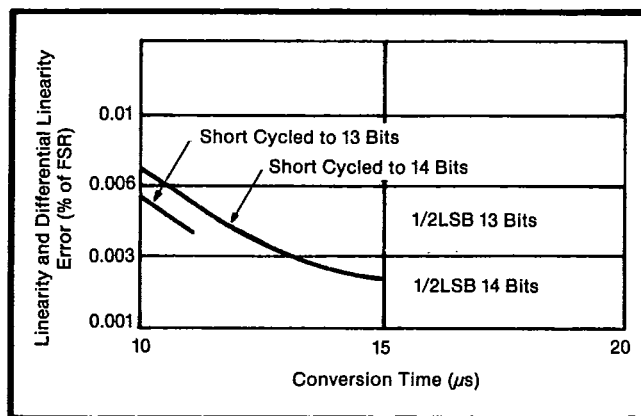

FIGURE 6. Linearity and Differential Linearity Versus Conversion Time.

## LAYOUT AND OPERATING INSTRUCTIONS

### LAYOUT PRECAUTIONS

Analog and digital common are not connected internally in the ADC76, but should be connected together as close to the unit as possible, preferably to a large plane under the ADC. If these grounds must be run separately, use wide conductor pattern and a  $0.01\mu F$  to  $0.1\mu F$  nonpolarized bypass capacitor between analog and digital commons at the unit. Low impedance analog and digital common returns are essential for low noise performance. Coupling between analog inputs and digital lines should be minimized by careful layout. The comparator input (pin 27) is extremely sensitive to noise. Any connection to this point should be as short as possible and shielded by Analog Common or  $\pm 15VDC$  supply patterns.

### POWER SUPPLY DECOUPLING

The power supplies should be bypassed with tantalum or electrolytic capacitors as shown in Figure 7 to obtain noise free operation. These capacitors should be located close to the ADC.

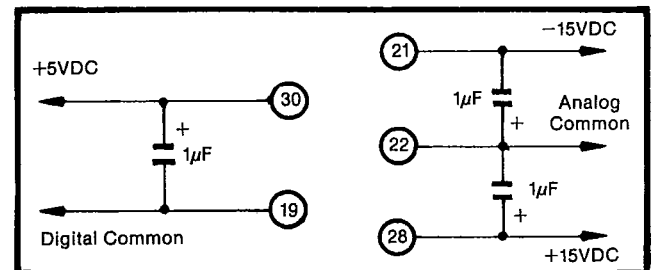

FIGURE 7. Recommended Power Supply Decoupling.

### INPUT SCALING

The analog input should be scaled as close to the maximum input signal range as possible in order to utilize the maximum signal resolution of the A/D converter. Connect the input signal as shown in Table II. See Figure 8 for circuit details.

TABLE II. ADC76 Input Scaling Connections.

Input Signal Range	Output Code	Connect Pin 26 To Pin	Connect Pin 24 To	Connect Input Signal To Pin
$\pm 10V$	COB or CTC*	27	Input Sig.	24
$\pm 5V$	COB or CTC*	27	Open	25
$\pm 2.5V$	COB or CTC*	27	Pin 27	25
0 to +5V	CSB	22	Pin 27	25
0 to +10V	CSB	22	Open	25
0 to +20V	CSB	22	Input Sig.	24

\*Obtained by inverting MSB pin 1.

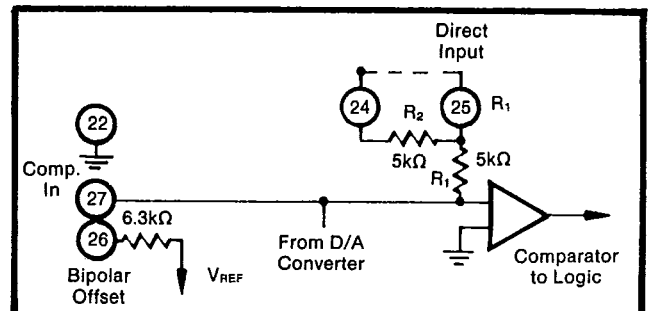

FIGURE 8. ADC76 Input Scaling Circuit.

**OUTPUT DRIVE**

Normally all ADC76 logic outputs will drive two standard TTL loads; however, if long digital lines must be driven, external logic buffers are recommended.

**INPUT IMPEDANCE**

The input signal to the ADC76 should be low impedance, such as the output of an op amp, to avoid any errors due to the relatively low input impedance of the ADC76.

If this impedance is not low, a buffer amplifier should be added between the input signal and the direct input to the ADC76 as shown in Figure 9.

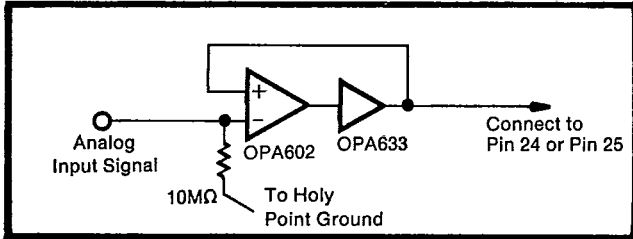

FIGURE 9. Source Impedance Buffering.

**OPTIONAL EXTERNAL GAIN AND OFFSET ADJUSTMENTS**

Gain and Offset errors may be trimmed to zero using external gain and offset trim potentiometers connected to the ADC as shown in Figures 10 and 11. Multiturn potentiometers with 100ppm/°C or better TCRs are recommended for minimum drift over temperature and time. These pots may be any value from 10kΩ to 100kΩ. All resistors should be 20% carbon or better. Pin 29 (Gain Adjust) and pin 27 (Offset Adjust) may be left open if no external adjustment is required; however, pin 29 should always be bypassed with 0.01μF to Analog Common.

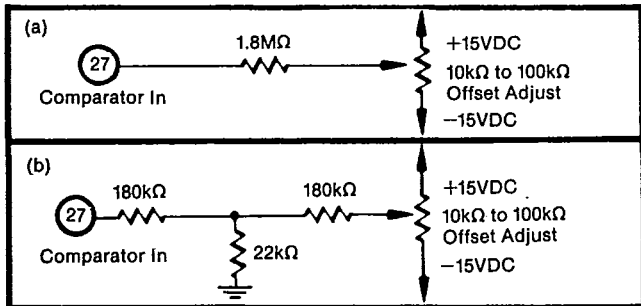

FIGURE 10. Two Methods of Connecting Optional Offset Adjust.

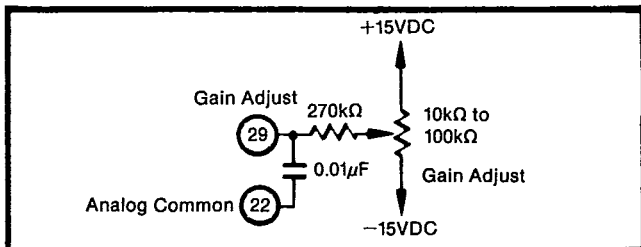

FIGURE 11. Connecting Optional Gain Adjust.

**ADJUSTMENT PROCEDURE**

Offset—Connect the Offset potentiometer (make sure R<sub>1</sub> is as close to pin 27 as possible) as shown in Figure 10.

Sweep the input through the end point transition voltage that should cause an output transition to all bits off ( $E_{IN}^{OFF}$ ), Figure 1.

Adjust the Offset potentiometer Until the actual end point transition voltage occurs at ( $E_{IN}^{OFF}$ ). The ideal transition voltage values of the input are given in Table I.

Gain—Connect the Gain adjust potentiometer as shown in Figure 11. Sweep the input through the end point transition voltage that should cause an output transition to all bits on ( $E_{IN}^{ON}$ ). Adjust the Gain potentiometer until the actual end point transition voltage occurs at ( $E_{IN}^{ON}$ ).

Table I details the transition voltage levels required.

**CONVERT COMMAND CONSIDERATIONS**

Convert command resets the converter whenever taken high. This insures a valid conversion on the first conversion after power-up.

Convert command must stay low during a conversion unless it is desired to reset the converter during a conversion.

**OPTIONAL CONVERSION TIME ADJUSTMENT**

The ADC76 may be operated with faster conversion times for resolutions less than 14 bits by connecting the Short Cycle (pin 32) as shown in Table III. Typical conversion times for the resolution and connections are indicated.

TABLE III. Short Cycle Connections for 12- to 16-Bit Resolutions.

Resolution (Bits)	16	15	14	13	12
Connect Pin 32 to	Open	Pin 16	Pin 15	Pin 14	Pin 13
Typical Conversion Time	17μs	16μs	15μs	13μs	12μs

Clock Rate Control may be connected to an external multiturn trim potentiometer with a TCR of ±10ppm/°C or less as shown in Figure 12. The typical conversion time versus the Clock Rate Control voltage is shown in Figure 13. The effect of varying the conversion time and the resolution on Linearity Error and Differential Linearity Error is shown in Figure 6.

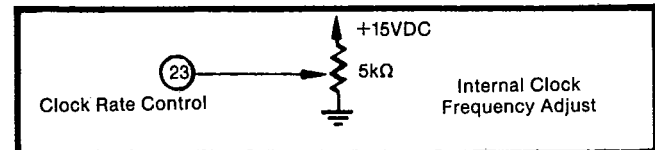

FIGURE 12. Clock Rate Control, Optional Fine Adjust.

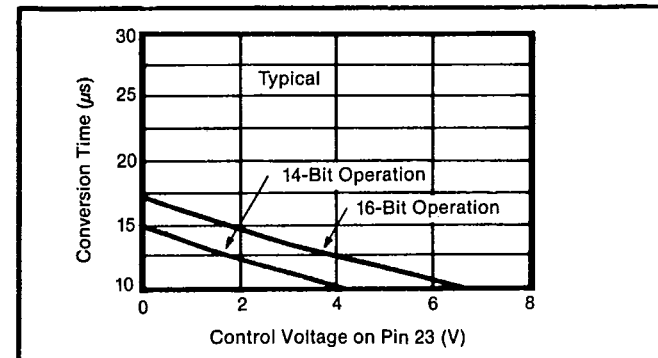

FIGURE 13. Conversion Time vs Clock Rate Control Voltage.