

SPECIFICATIONS **CLA30G2C**
OUTLINES DIMENSIONS
Description

- *Round Type
- *T1 (3mm) Diameter
- *Lens Color: Water Clear
- *With Flange

Features

- *Emitting Color: Green
- *High Luminous Intensity
- *Technology: InGaAlP

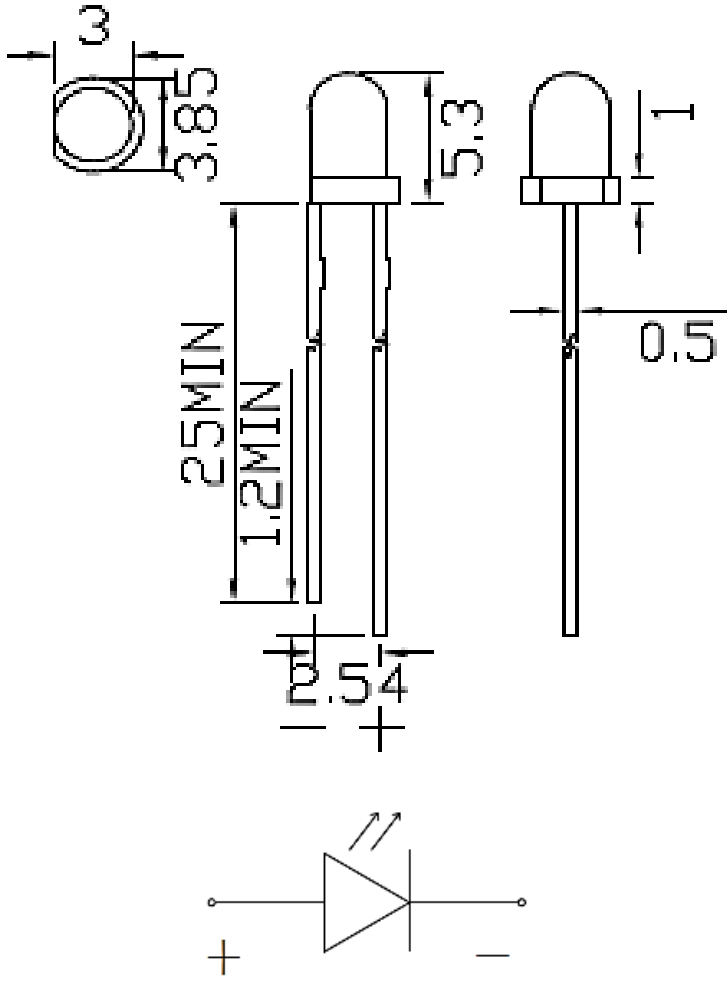

- Notes:
1. All Dimensions are in millimeters (inches).
 2. Tolerance is $\pm 0.25\text{mm}$ (0.01") unless otherwise noted.
 3. Specifications are subject to change without notice.

| Part Number | Chip Material | Color of Emission | Lens Type | Viewing Angle |
|-------------|---------------|-------------------|-------------|---------------|
| CLA30G2C | InGaAlP | Green | Water Clear | 20° |



ChromeLED Corp. reserves the right to make changes at any time in order to supply the best product possible. The most current version of this document will always be available at: www.chromeled.com

ABSOLUTE MAXIMUM RATINGS
(TA=25°C)

| Parameter | Symbol | Max Rating | Unit |
|---|--------|------------|------|
| Power Dissipation | PD | 60 | mW |
| Pulse Current Forward Current | IFP | 60 | mA |
| Continuous Forward Current | IF | 30 | mA |
| Reverse Voltage | VR | 5 | V |
| Operating Temperature Range | TOPR | -25~+85 | °C |
| Storage Temperature Range | TSTG | -30~+85 | °C |
| IFP = Pulse Width ≤ 10 ms, Duty Ratio ≤ 1/10. Soldering Condition: 260 °C/ 5sec | | | |

OPTICAL-ELECTRICAL CHARACTERISTICS
(TA=25°C)

| Parameter | Symbol | Test Condition | Value | | | Unit |
|-------------------------|--------|----------------|-------|-----|-----|------|
| | | | Min | Typ | Max | |
| Luminous Intensity | IV | IF = 20mA | 300 | 400 | - | mcd |
| Forward Voltage | VF | IF = 20mA | - | 2.1 | 2.4 | V |
| Reverse Leakage Current | IR | VR = 5V | - | - | 10 | μA |
| Viewing Angle | 2θ1/2 | IF = 20mA | - | 20 | - | deg |
| Dominant Wavelength | λD | IF = 20mA | 568 | - | 573 | nm |

*Tolerance of viewing angle: -10 / +5 deg.



ChromeLED Corp. reserves the right to make changes at any time in order to supply the best product possible. The most current version of this document will always be available at: www.chromeled.com

OPTICAL CHARACTERISTIC CURVES

Forward Current vs. Forward Voltage

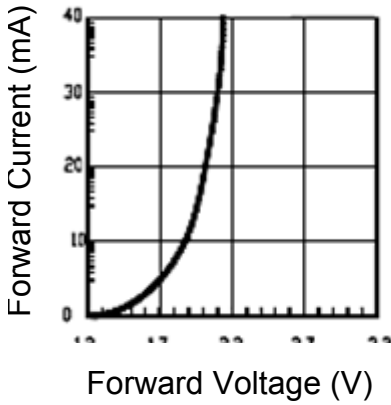

Forward Current vs. Relative Luminous Intensity

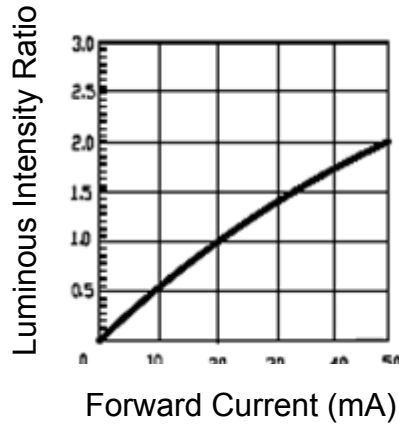

Forward Current vs. Ambient Temperature

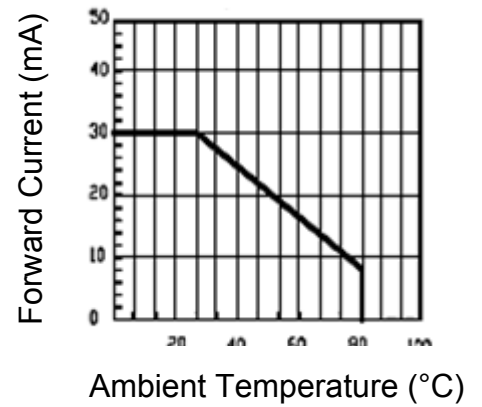

Relative Luminous Intensity vs. Ambient Temperature

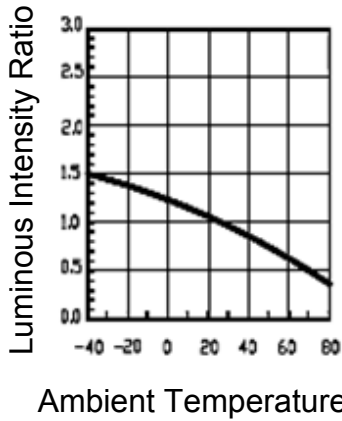

Relative Luminous Intensity vs. Main Wavelength

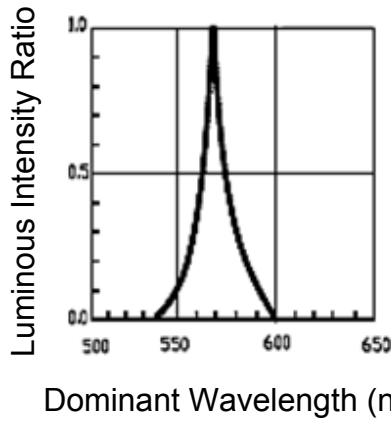

Radiation Diagram

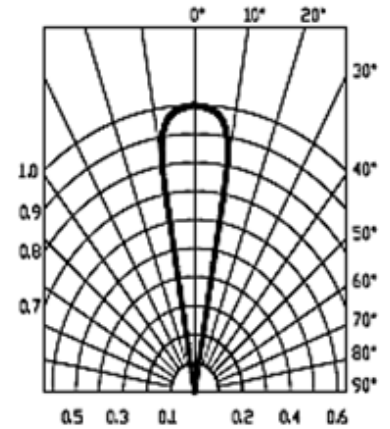

SOLDERING CONDITIONS – LAMP TYPE LED

* Solder the LED no closer than 3mm from the base of the epoxy bulb. Soldering beyond the base of the tie bar is recommended.

* Recommended soldering conditions

| Dip Soldering | |
|-------------------------|--|
| Pre-Heat | 100 °C Max |
| Pre-Heat Time | 60 Second Max |
| Solder Bath Temperature | 260 °C Max |
| Dipping Time | 5 Second Max |
| Dipping Position | No lower than 3mm from the base of the epoxy |

| Hand Soldering | | |
|----------------|---|---|
| | 3mm Series | Others |
| Temperature | 300 °C Max | 350 °C Max |
| Soldering Time | 3 Second Max | 3 Second Max |
| Position | No closer than 3mm from the base of the epoxy | No closer than 3mm from the base of the epoxy |

* Do not apply any stress to the lead. Particularly when heated.

* The LED must not be repositioned after soldering.

* After soldering the LEDs, the epoxy bulb should be protected from mechanical shock or vibration until the LEDs return to room temperature.

* Direct soldering onto a PC board should be avoided. Mechanical stress to the resin may be caused by the PC board warping or from the clinching and cutting of the leadframes. When it is absolutely necessary, the LEDs may be mounted in this fashion, but, the user will assume responsibility for any problems. Direct soldering should only be done after testing has confirmed that no damage, such as wire bond failure or resin deterioration, will occur. LEDs should not be soldered directly to double sided PC boards because the heat will deteriorate the epoxy resin.

* When it is necessary to clamp the LEDs to prevent soldering failure, it is important to minimize the mechanical stress on the LEDs.

* Cut the LED leadframes at room temperature. Cutting the leadframes at high temperature may cause LED failure.



ChromeLED Corp. reserves the right to make changes at any time in order to supply the best product possible. The most current version of this document will always be available at: www.chromeled.com