

## Bi-directional ESD Protection Diode

### DESCRIPTIONS

The TESDL5V0B20P1M5 is Bidirectional ESD rated clamping cell to protect power interfaces, or one control line, or one low speed data line in an electronic system. It has been specifically designed to protect sensitive electronic components which are connected to power and control lines from over-voltage damage by Electrostatic Discharging (ESD), and Lightning.

TESDL5V0B20P1M5 is a unique design which includes proprietary clamping cells in a small package.

During transient conditions, the proprietary clamping cells prevent over-voltage on the control/data/power lines, protecting any downstream components.

The TESDL5V0B20P1M5 may be used to provide ESD protection up to  $\pm 30\text{kV}$  (contact and air discharge) according to IEC61000-4-2, and withstand peak pulse current up to 6A (8/20 $\mu\text{s}$ ) according to IEC61000-4-5.



### FEATURES

- ESD protect for 1 line with bidirectional
- Provide ESD protection for each channel to IEC 61000-4-2 (ESD)  $\pm 30\text{kV}$  (air),  $\pm 30\text{kV}$  (contact) IEC 61000-4-5 (Lightning) 6A (8/20 $\mu\text{s}$ )
- Suitable for 5V and below, operating voltage applications
- Small package saves board space
- Protect one I/O line or one power line
- Fast response time
- Low leakage
- RoHS Compliant
- Halogen-Free according to IEC 61249-2-21

### APPLICATION

- Computers and peripherals
- Power supply protection
- Portable devices
- Audio and video equipment
- Notebooks, desktops, and servers

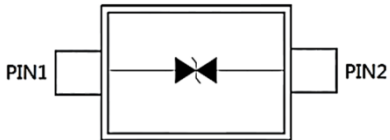

PACKAGE: SOD-523F	PIN CONFIGURATION		CIRCUIT DIAGRAM
			
	PIN 1	Anode 1	
	PIN 2	Anode 2	

<b>ABSOLUTE MAXIMUM RATINGS</b> ( $T_A = 25^\circ\text{C}$ unless otherwise noted)			
PARAMETER	SYMBOL	VALUE	UNIT
Peak pulse power ( $t_p = 8/20\mu\text{s}$ )	$P_{PK}$	84	W
Peak pulse current ( $t_p = 8/20\mu\text{s}$ )	$I_{PP}$	6	A
ESD according to IEC61000-4-2 air discharge	$V_{ESD}$	$\pm 30$	kV
ESD according to IEC61000-4-2 contact discharge		$\pm 30$	kV
Operating junction temperature range	$T_J$	-55 to +150	$^\circ\text{C}$
Storage temperature range	$T_{STG}$	-55 to +150	$^\circ\text{C}$

<b>ELECTRICAL SPECIFICATIONS</b> ( $T_A = 25^\circ\text{C}$ unless otherwise noted)						
PARAMETER	CONDITIONS	SYMBOL	MIN	TYP	MAX	UNIT
Reverse working voltage		$V_{RWM}$	-	-	5	V
Reverse breakdown voltage	$I_R = 1\text{mA}$ , $T_J = 25^\circ\text{C}$	$V_{BR}$	6	-	-	V
Reverse leakage current	$V_{RWM} = 5\text{V}$ , $T_J = 25^\circ\text{C}$	$I_R$	-	-	100	nA
Clamping voltage <sup>(1)</sup>	$I_{PP} = 1\text{A}$ , $t_p = 8/20\mu\text{s}$	$V_C$	-	-	9.0	V
	$I_{PP} = 3\text{A}$ , $t_p = 8/20\mu\text{s}$		-	-	10.7	V
	$I_{PP} = 5\text{A}$ , $t_p = 8/20\mu\text{s}$		-	-	13.5	V
	$I_{PP} = 6\text{A}$ , $t_p = 8/20\mu\text{s}$		-	-	14.0	V
Clamping voltage <sup>(2)</sup>	$I_{TLP} = 16\text{A}$ , $t_p = 100\text{ns}$	$V_{CL}$	-	12	-	V
Junction capacitance	1MHz, $V_R = 0\text{V}$	$C_J$	-	12.7	20	pF
Dynamic resistance <sup>(2)</sup>		$R_{DYN}$	-	0.3	-	$\Omega$

**Notes:**

1. Non-repetitive current pulse, according to IEC61000-4-5.
2. TLP parameter:  $Z_0 = 50\ \Omega$ ,  $t_p = 100\text{ns}$ ,  $t_r = 2\text{ns}$ , averaging window from 60ns to 80ns.  $R_{DYN}$  is calculated from 4A to 16A.

<b>ORDERING INFORMATION</b>		
ORDERING CODE	PACKAGE	PACKING
TESDL5V0B20P1M5 RKG	SOD-523F	3,000 / 7" Tape & Reel

**CHARACTERISTICS CURVES**

( $T_A = 25^\circ\text{C}$  unless otherwise noted)

**Fig.1 Peak Pulse Power vs. Junction Temperature**

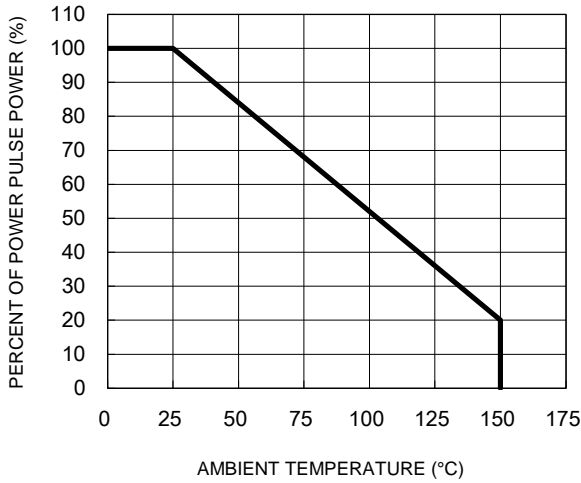

**Fig.2 Non-Repetitive Peak Pulse Power vs. Pulse Time**

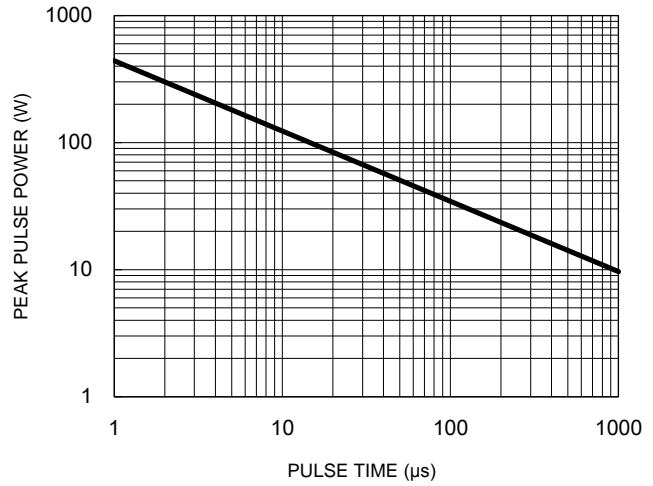

**Fig.3 Clamping Voltage vs. Peak Pulse Current**

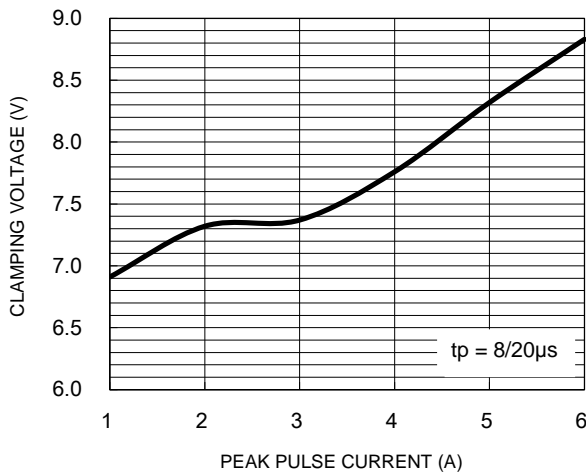

**Fig.4 Capacitance vs. Reverse Voltage**

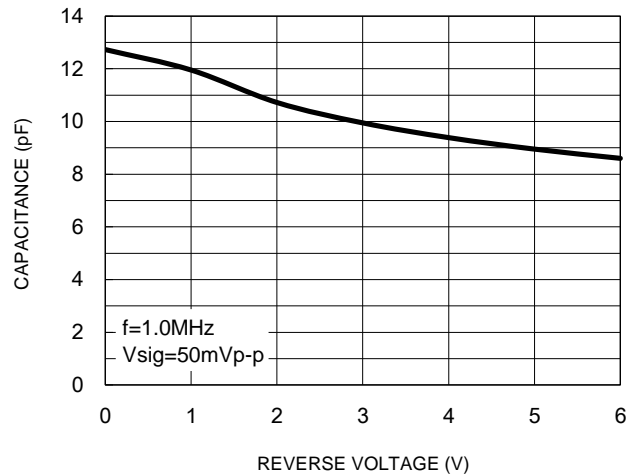

**Fig.5 TLP Curve**

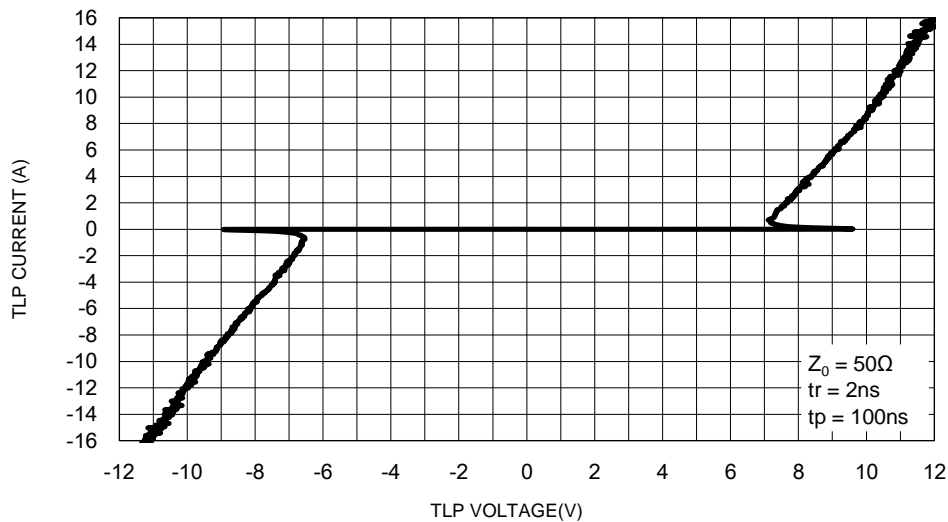

**CHARACTERISTICS CURVES**

( $T_A = 25^\circ\text{C}$  unless otherwise noted)

**Fig.6 8/20 $\mu\text{s}$  pulse waveform**

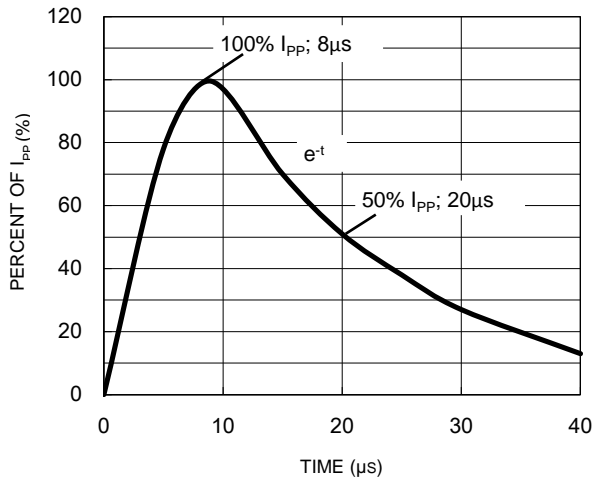

**Fig.7 ESD pulse waveform**

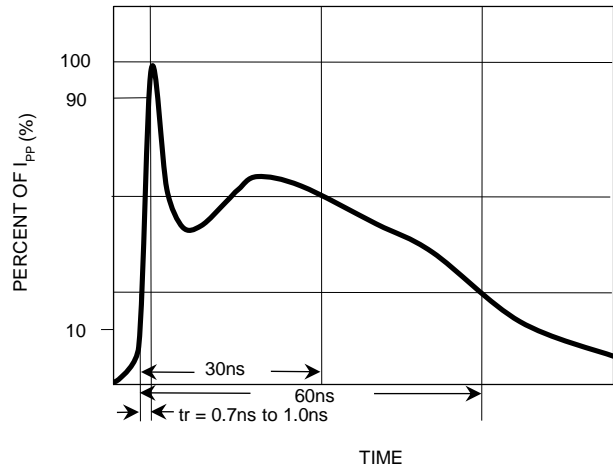

**APPLICATION INFORMATION**

**Device Connection**

The TESDL5V0B20P1M5 is designed to protect one line against system ESD Lightning pulses by clamping it to an acceptable reference. It provides bidirectional protection. The usage of the TESDL5V0B20P1M5 is shown in Fig1. Protected line, such as data line, control line, or power line. In order to minimize parasitic inductance in the board traces, all path lengths connected to the pins of TESDL5V0B20P1M5 should be kept as short as possible.

In order to obtain enough suppression of ESD induced transient, good circuit board is critical. Thus, the following guidelines are recommended:

- Let the path length between the protected lines and the TESDL5V0B20P1M5 minimize.
- Place the TESDL5V0B20P1M5 near the input terminals or connectors to restrict transient coupling.
- The ESD current return path to ground should be kept as short as possible.
- Use ground planes whenever possible.

**Fig.1 ESD protection by TESDL5V0B20P1M5**

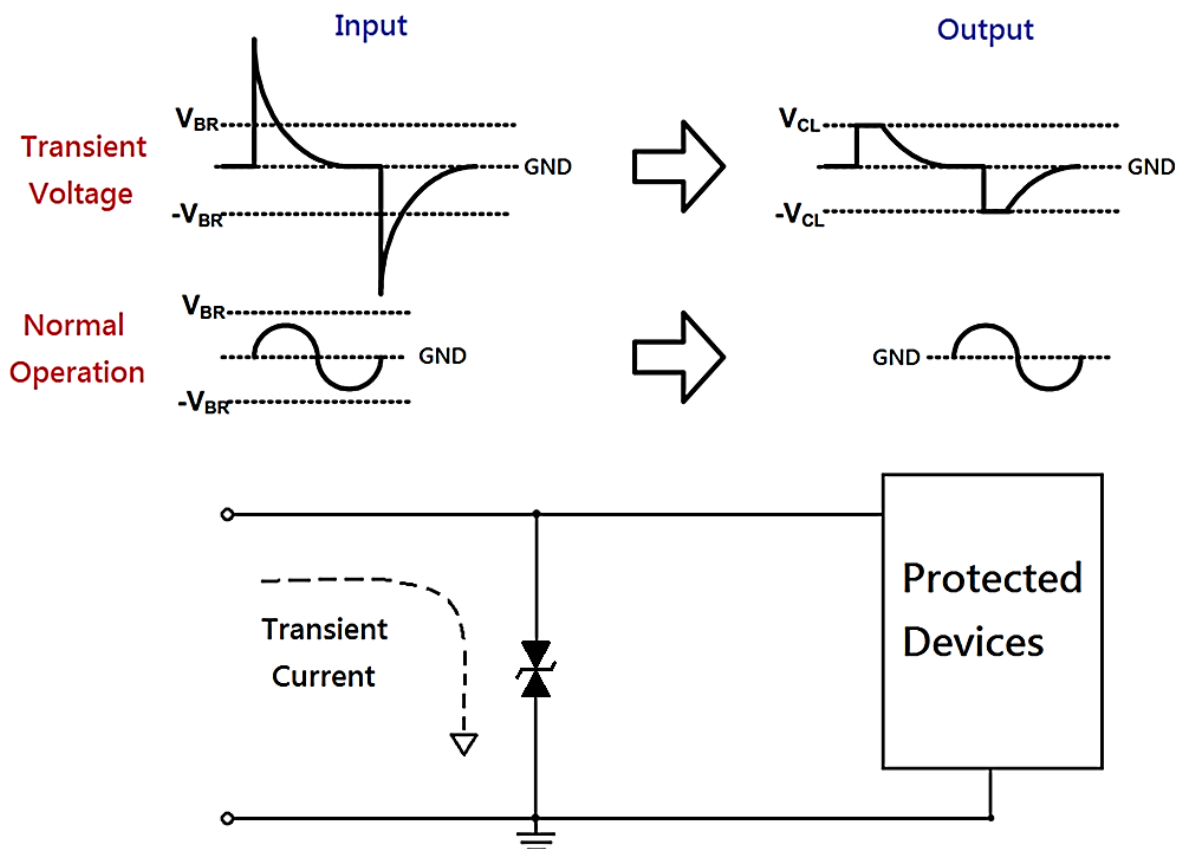

**PACKAGE OUTLINE DIMENSIONS**

**SOD-523F**

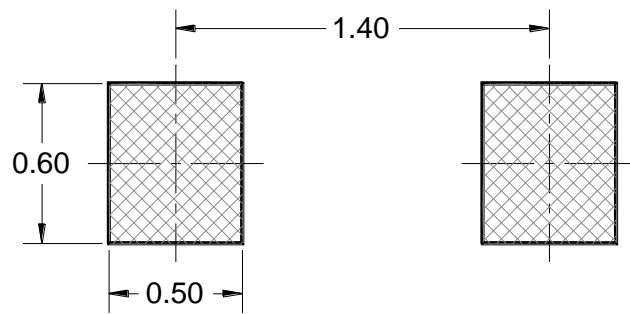
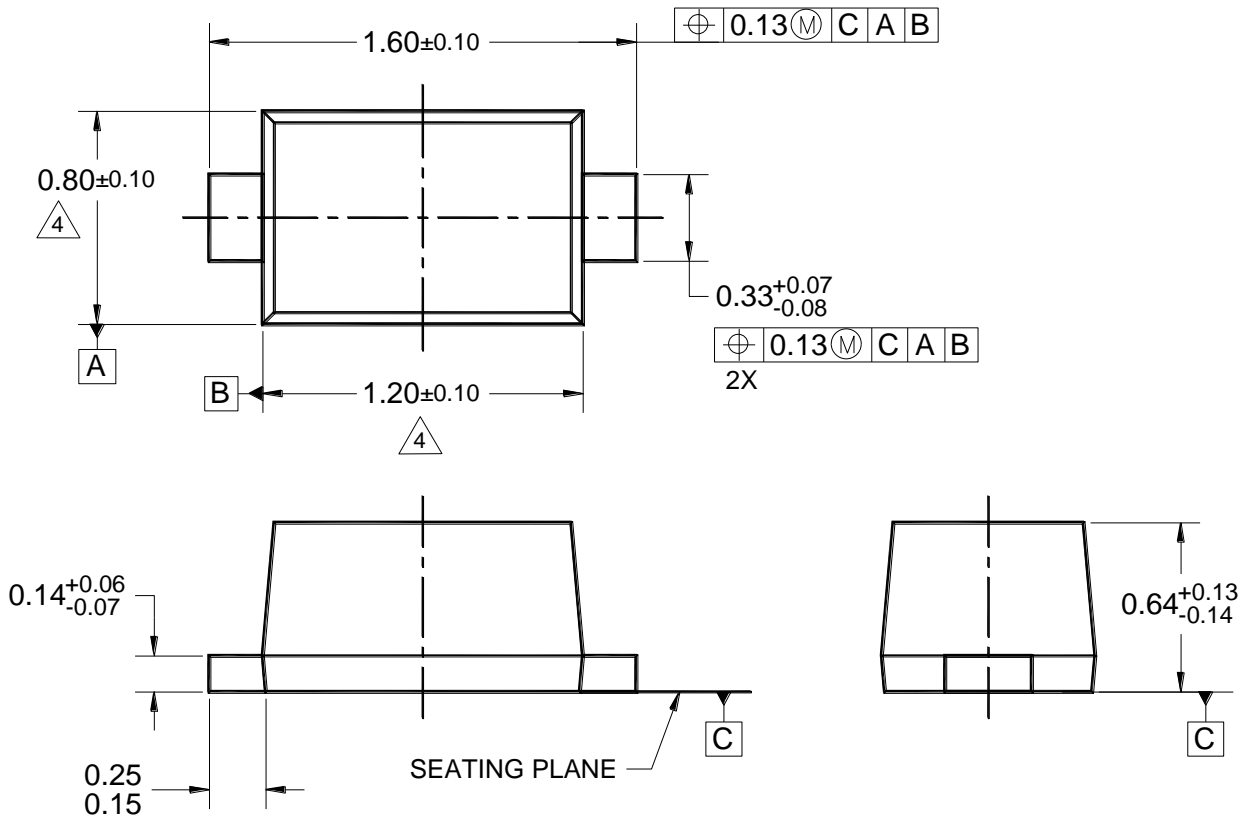

**SUGGESTED PAD LAYOUT**

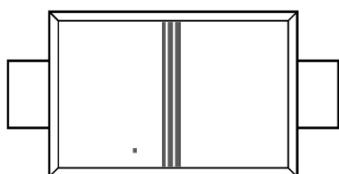

**MARKING DIAGRAM**

**NOTES: UNLESS OTHERWISE SPECIFIED**

1. ALL DIMENSIONS ARE IN MILLIMETERS.
2. DIMENSIONING AND TOLERANCING PER ASME Y14.5M-1994.
3. PACKAGE OUTLINE REFERENCE: EIAJ ED-7500A, SC-79.
4. MOLDED PLASTIC BODY LATERAL DIMENSIONS DO NOT INCLUDE MOLD FLASH.
5. DWG NO. REF: HQ2SD07-SOD523F-047 REV A.

## **Notice**

Specifications of the products displayed herein are subject to change without notice. TSC or anyone on its behalf assumes no responsibility or liability for any errors or inaccuracies.

Purchasers are solely responsible for the choice, selection, and use of TSC products and TSC assumes no liability for application assistance or the design of Purchasers' products.

Information contained herein is intended to provide a product description only. No license, express or implied, to any intellectual property rights is granted by this document. Except as provided in TSC's terms and conditions of sale for such products, TSC assumes no liability whatsoever, and disclaims any express or implied warranty, relating to sale and/or use of TSC products including liability or warranties relating to fitness for a particular purpose, merchantability, or infringement of any patent, copyright, or other intellectual property right.

The products shown herein are not designed for use in medical, life-saving, or life-sustaining applications. Customers using or selling these products for use in such applications do so at their own risk and agree to fully indemnify TSC for any damages resulting from such improper use or sale.