



100QBW4_2.25 Series

100W Quarter-Brick - Single Output DC-DC Converter - Wide Input - Isolated & Regulated

DC-DC Converter

100 Watt

- ⊕ Wide Input voltage range (4:1)
- ⊕ High efficiency up to 94%
- ⊕ Short circuit protection (SCP)
- ⊕ Input under-voltage, over-current, over-voltage, over-temperature protection
- ⊕ Isolation: 2.25KVDC
- ⊕ Operating temperature range: -40°C to +85°C
- ⊕ Five-sided metal shielding package
- ⊕ International standard pin-out: 1/4 brick

The 100QBW4_2.25 series offers 4:1 input voltage, efficiency up to 94%, 2250VDC isolation, Input under-voltage protection, output short circuit protection, over-current protection, over-voltage protection, over-temperature protection and EMI meets CISPR22/EN55022 CLASS B.

All models are widely applied in battery power supplies, industrial control, electricity, instruments, railway, communication fields.



Common specifications	
Short circuit protection*:	Hiccup, continuous, automatic recovery
Cooling:	Natural or forced convection
Operation temperature range:	-40°C~+85°C
Storage temperature range:	-55°C ~+125°C
Over temperature protection:	+95°C MIN / +105°C TYP / +115°C MAX
Pin welding resistance temperature:	300°C MAX, 1.5mm from case for 10sec.
Storage humidity range:	< 95%
Vibration:	IEC/EN61373 car body 1 B mold
Trim**:	95%Vo MIN, 110%Vo MAX
Sense:	105%Vo MAX
Case material:	Plastic [UL94-V0] / aluminium
MTBF:	500,000 hours
Weight:	70g / 90g (with base-plate)

* Supply voltage must be discontinued at the end of short circuit duration.
 ** 100QBW4_4805S2.25 and 100QBW4_4815S2.25, Trim and Sense function meet output up to 10%, Vin need exceed 20VDC.

Input specifications

Item	Test condition	Min	Typ	Max	Units
Input current	full load/no load		2265/ 50	2341/ 80	mA
Reflected ripple current	Nominal Vin and full load		30		mA
Surge voltage	1sec. max.	-0.7		90	VDC
Start-up threshold voltage	100% load			18	VDC
Input under voltage protection	• 100QBW4_4805S1.5, 100QBW4_4815S1.5 • Others	16	16.5		VDC
		15	15.5		VDC
Input filter	Pi Type				
Hot plug	Unavailable				
Ctrl (the voltage of Ctrl pin is relative to input pin GND)	• Module switch ON			Ctrl suspended or connected to TTL high level (3.5-12VDC)	
	• Module switch OFF			Ctrl pin connected to GND or low level (0-1.2VDC)	
	• Input current when switched OFF		2	10	mA

Output specifications

Item	Test condition	Min	Typ	Max	Units
Output voltage accuracy			±1	±3	%
Line regulation			±0.2	±0.5	%
Load regulation			±0.5	±0.75	%
Transient recovery time	25% load step change		200	500	µs
Transient response deviation	25% load step change • 5V output • others		±3	±7.5	%
			±3	±5	%
Temperature coefficient				±0.03	%/°C
Ripple & Noise*	20MHz Bandwidth • 12V/15V output • others		100	200	mVp-p
			130	250	mVp-p
Output over-voltage protection	Input voltage range	110	125	160	%Vo
Output over-current protection	Input voltage range	110	125	190	%Io
Switching frequency	PFM mode		250		KHz

*Test ripple and noise by "parallel cable" method.

Isolation specifications

Item	Test condition	Min	Typ	Max	Units
Isolation voltage	Tested for 1 minute and leak current less than 5mA	2250			VDC
Isolation resistance	Insulation voltage 500VDC	1000			MΩ
Isolation capacitance	Input-output, 100KHz/0.1V		2200		pF

Example:

100QBW4_4805S2.25
100= 100 Watt; QB= Quarter-Brick; W4= Wide input (4:1);
48= 18-75 Vin; 05= 5Vout; S= Single Output; 2.25= 2.25kVDC isolation

Note:

- Operation under minimum load will not damage the converter; However, they may not meet all specification listed, and that will reduce the life of product.
- All specifications measured at Ta=25°C, humidity<75%, nominal input voltage and rated output load unless otherwise specified.
- In this datasheet, all the test methods of indications are based on corporate standards.

100QBW4_2.25 Series

100W Quarter-Brick - Single Output DC-DC Converter - Wide Input - Isolated & Regulated

EMC specifications				
EMI	CE	CISPR22/EN55022, EN50121-3-2	CLASS A and CLASS B (see EMC recommended circuit)	
EMI	RE	CISPR22/EN55022, EN50121-3-2	CLASS A and CLASS B (see EMC recommended circuit)	
EMS	ESD	IEC/EN61000-4-2, EN50121-3-2	Contact $\pm 6\text{KV}$ /Air $\pm 8\text{KV}$	perf. Criteria B
EMI	RS	IEC/EN61000-4-3, EN50121-3-2	20V/m	perf. Criteria A
EMI*	EFT	IEC/EN61000-4-4, EN50121-3-2	$\pm 2\text{KV}$ (see EMC recommended circuit)	perf. Criteria A
EMS	Surge	EN50121-3-2	differential mode $\pm 1\text{KV}$, 1.2/50 μs , source impedance 4 Ω (see EMC recommended circuit)	perf. Criteria B
EMI	CS	IEC/EN61000-4-6, EN50121-3-2	10 Vr.m.s	perf. Criteria A

Part Number	Input Voltage [V]		Output Voltage [VDC]	Output Current [A, max]	Efficiency [%, Typ]		Capacitive load [A, max]
	Nominal	Range			Vin=24V	Vin=48V	
100QBW4_4805S2.25	48	18-75	5	20	93	91	6000
100QBW4_4812S2.25	48	18-75	12	8.3	93	92	2000
100QBW4_4815S2.25	48	18-75	15	6.7	92	93	2000
100QBW4_4824S2.25	48	18-75	24	4.2	93	92	1000
100QBW4_4848S2.25	48	18-75	48	2.1	93	92	470

For aluminium base-plate add -BP at the end, f.ex. 100QBW4_xxyyS2.25-BP.

Temperature derating curves

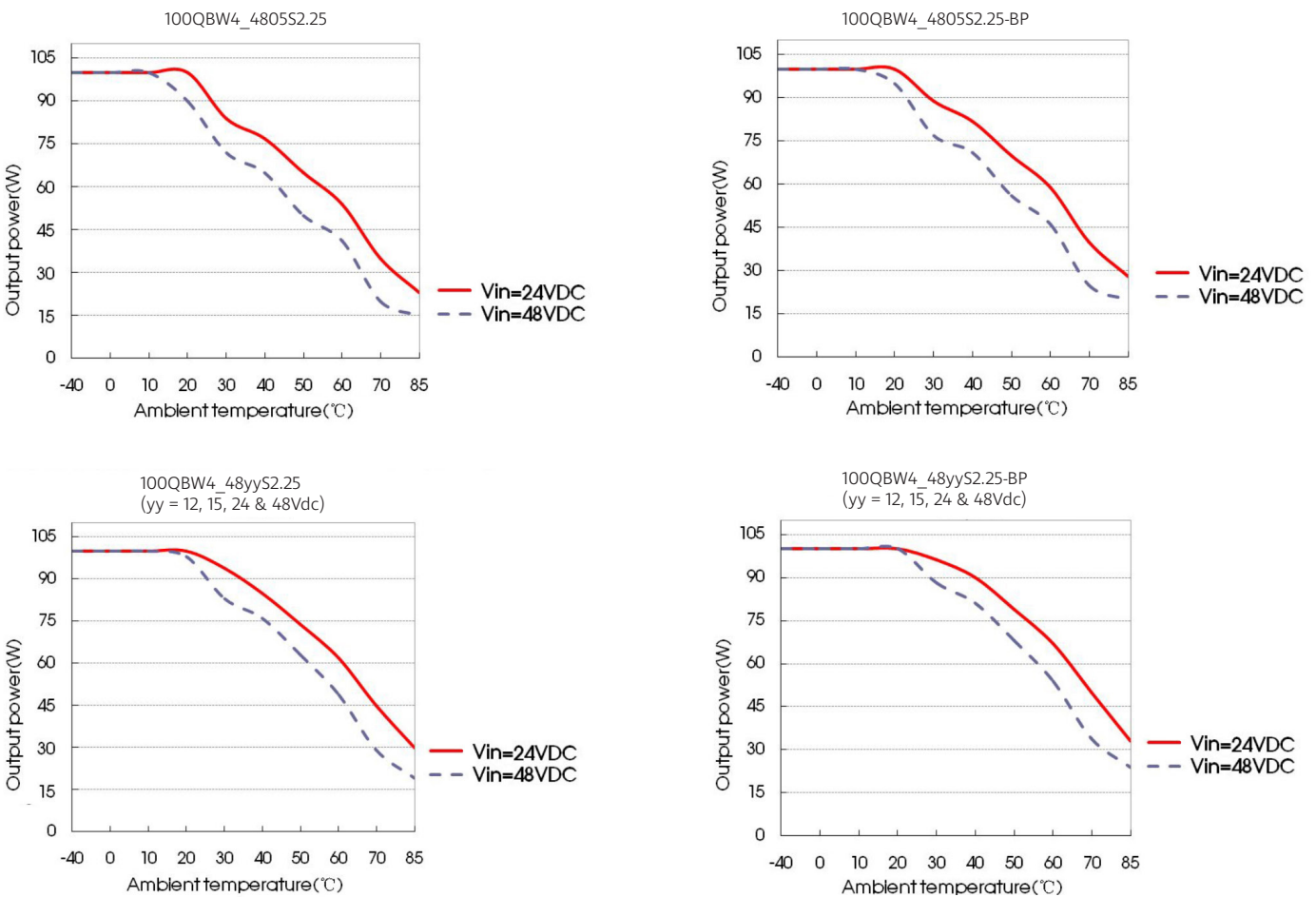

100QBW4_2.25 Series

100W Quarter-Brick - Single Output DC-DC Converter - Wide Input - Isolated & Regulated

Sense of application and precautions

When not using remote sense

Notes:

1. When not using remote sense, make sure +Vo and Sense + are shorted, and that 0V and Sense- are shorted as well;
2. Keep the tracks between +Vo and Sense +, 0V and Sense- as short as possible. and close to the terminal. Avoid a looping track. If noise interferes the loop, the operation of the power module will become unstable.

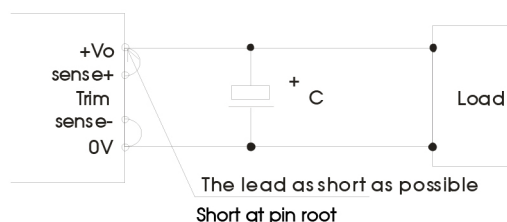

When remote sense is used

Notes:

1. Using remote sense with long wires may cause output voltage to become unstable. Consult us if long sensing wiring is necessary.
2. Sense tracks or wires should be as short as possible. If using wires, it should not use twisted-pair or shielded wires.
3. Please use wide PCB tracks or a thick wires between the power supply module and the load, the line voltage drop should be kept less than 0.3V. Make sure the power supply module's output voltage remains within the specified range.
4. The impedance of wires may cause the output voltage oscillation or a greater ripple, please take adequate assessments before using.

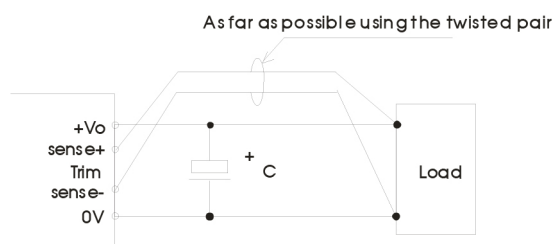

Typical application

If not using Gaptec's recommended circuit, please ensure an 220 μ F electrolytic capacitors in parallel with the input, which used to suppress the surge voltage come from the input terminal. All the DC/DC converters of this series are tested according to the recommended circuit (see Fig. 1) before delivery.

If it is required to further reduce input&output ripple, properly increase the input & output of additional capacitors Cin and Cout or select capacitors of low equivalent impedance, provided that the capacitance is no larger than the max. capacitive load of the product.



Vout (VDC)	Fuse	Cin	Cout
5	10A, slow blow	220 μ F	470 μ F
12/15	10A, slow blow	220 μ F	220 μ F
24	10A, slow blow	220 μ F	100 μ F
48	10A, slow blow	220 μ F	100 μ F

100QBW4_2.25 Series

100W Quarter-Brick - Single Output DC-DC Converter - Wide Input - Isolated & Regulated

EMC solution recommended circuit

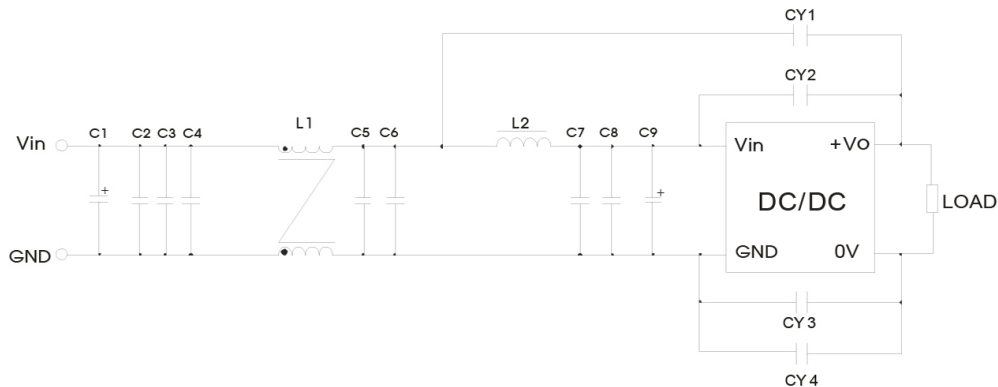

Device number CLASS A/B	Device parameter	Device function
C1	150 μ F electrolytic capacitor	Meet pulse group and surge
C9	47 μ F electrolytic capacitor	
C1	150 μ F electrolytic capacitor	Meet conducted emission and radiated emission
C9	47 μ F electrolytic capacitor	
C2, C3, C4, C5, C6, C7, C8	2.2 μ F ceramic capacitor	
L1	1.0mH common mode inductor	
L2	1.5 μ H inductance	
CY3 (CLASS A)	1nF Y1 safety capacitor	
CY1, CY2, CY3, CY4 (CLASS B)	1nF Y1 safety capacitor	

Trim application & trim resistance

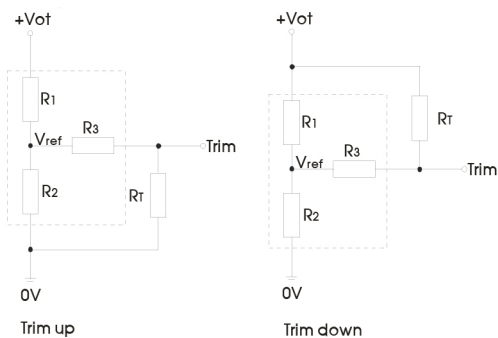

Calculation formula of Trim resistance:

$$\begin{aligned} \text{up: } R_T &= \frac{\alpha R_2}{R_2 - \alpha} - R_3 & \alpha &= \frac{V_{ref}}{V_{o'} - V_{ref}} \cdot R_1 \\ \text{down: } R_T &= \frac{\alpha R_1}{R_1 - \alpha} - R_3 & \alpha &= \frac{V_{o'} - V_{ref}}{V_{ref}} \cdot R_2 \end{aligned}$$

Application circuit for TRIM (Part in broken line is the interior of models)
 Note: R_T is Trim resistance, α is a self-defined parameter, with no real meaning. $V_{o'}$ for the actual needs of the up or down regulated voltage.

Vout(V)	R1(K Ω)	R2(K Ω)	R3(K Ω)	Vref(V)
5	3.036	3	10	2.5
12	11.000	2.87	15	2.5
15	14.03	2.8	15	2.5
24	24.872	2.87	15	2.5
48	53.017	2.913	15	2.5

When the Trim function with down regulated is used, If the R_T resistor is too low or "Trim" is short with "+Vo", the output voltage $V_{o'}$ would be lower than $0.9V_o$, which may cause the product to be irreversibly damaged.

It is not allowed to connect modules output in parallel to enlarge the power.

100QBW4_2.25 Series

100W Quarter-Brick - Single Output DC-DC Converter - Wide Input - Isolated & Regulated

Mechanical dimensions and recommended layout

100QBW4_xxyyS2.25

THIRD ANGLE PROJECTION 

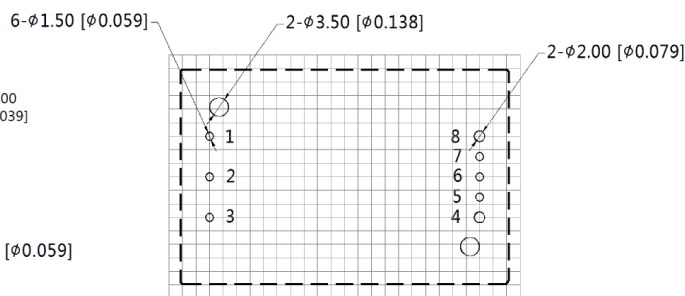
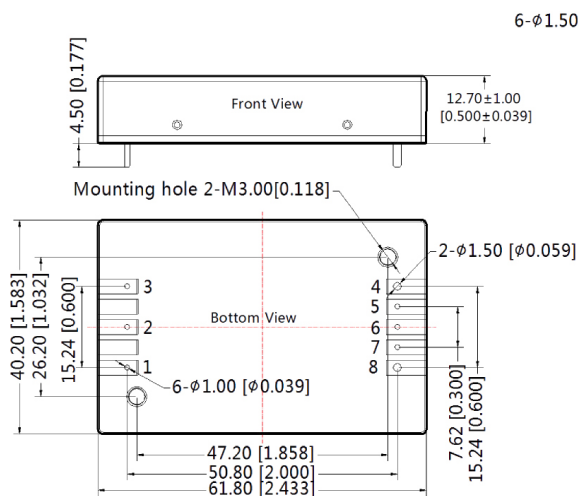

Note: Grid 2.54*2.54mm

Pin-Out			
Pin	Function	Pin	Function
1	+Vin	5	Sense-
2	Ctrl	6	Trim
3	-Vin	7	Sense+
4	0V	8	+Vo

Note:
 Unit: mm[inch]
 Pin1, 2, 3, 5, 6, 7's diameter: 1.00[0.039]
 Pin4, 8's diameter: 1.50[0.059]
 Pin diameter tolerances: ±0.10[±0.004]
 General tolerances: ±0.50[±0.020]
 Mounting hole screwing torque: Max 0.4 N·m

Base-plate dimensions and recommended layout

100QBW4_xxyyS2.25-BP

THIRD ANGLE PROJECTION 

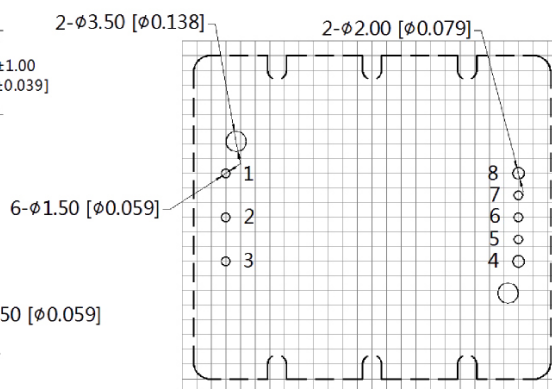
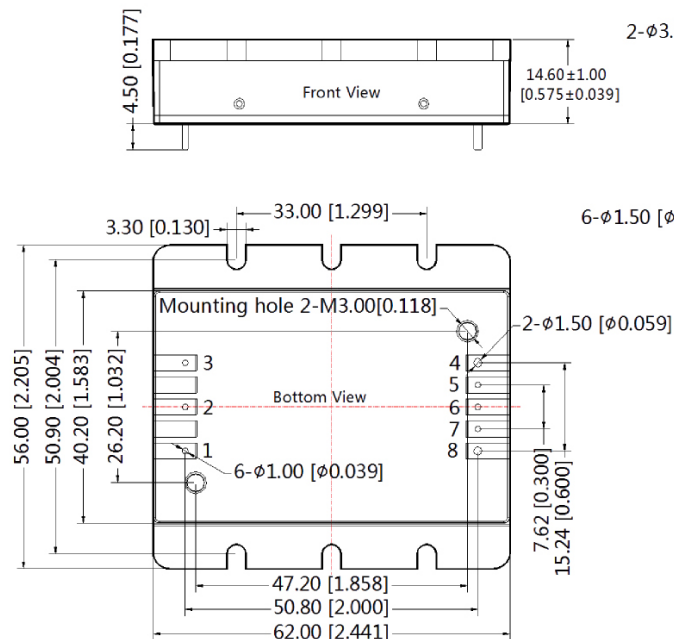

Note: Grid 2.54*2.54mm

Pin-Out			
Pin	Function	Pin	Function
1	+Vin	5	Sense-
2	Ctrl	6	Trim
3	-Vin	7	Sense+
4	0V	8	+Vo

Note:
 Unit: mm[inch]
 Pin1, 2, 3, 5, 6, 7's diameter: 1.00[0.039]
 Pin4, 8's diameter: 1.50[0.059]
 Pin diameter tolerances: ±0.10[±0.004]
 General tolerances: ±0.50[±0.020]
 Mounting hole screwing torque: Max 0.4 N·m