

# GSID100A120T2P2

## IGBT PIM Module



### Features:

- Short Circuit Rated 10 $\mu$ s
- Low Saturation Voltage:  $V_{CE(sat)} = 1.90V @ I_C = 100A, T_C = 25^\circ C$
- Low Switching Loss
- 100% RBSOA Tested ( $2 \times I_C$ )
- Low Stray Inductance
- Lead Free, Compliant with RoHS Requirement



### Applications:

- Industrial Inverters
- Servo Applications

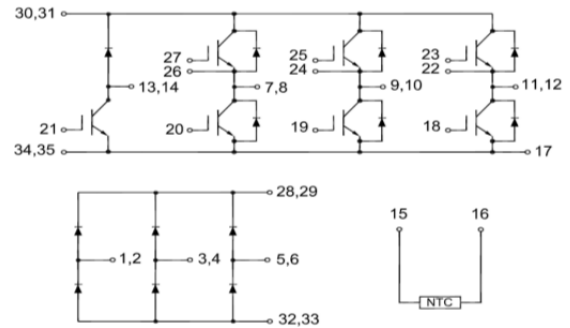

### IGBT, Inverter

#### Maximum Rated Values ( $T_C = 25^\circ C$ Unless otherwise specified)

$V_{CES}$	Collector-Emitter Blocking Voltage		1200	V
$V_{GES}$	Gate-Emitter Voltage		$\pm 20$	V
$I_C$	Continuous Collector Current	$T_C = 80^\circ C$	100	A
		$T_C = 25^\circ C$	200	A
$I_{CM}$	Repetitive Peak Collector Current	$T_J = 175^\circ C$	200	A
$t_{SC}$	Short Circuit Withstand Time		>10	$\mu s$
$P_D$	Maximum Power Dissipation per IGBT	$T_C = 25^\circ C$ $T_{Jmax} = 175^\circ C$	710	W

### Electrical Characteristics of IGBT ( $T_C=25^{\circ}\text{C}$ Unless otherwise specified)

#### Static characteristics

Symbol	Description	Conditions	Min	Typ	Max	Unit
$V_{GE(th)}$	Gate-Emitter Threshold Voltage	$I_C = 1 \text{ mA}, V_{CE} = V_{GE}$	5.0	5.5	6.0	V
$V_{CE(sat)}$	Collector-Emitter Saturation Voltage	$I_C = 100 \text{ A}, V_{GE} = 15\text{V}$	$T_J = 25^{\circ}\text{C}$	1.90	2.10	V
			$T_J = 125^{\circ}\text{C}$	2.20		V
$I_{CES}$	Collector-Emitter Leakage Current	$V_{GE} = 0\text{V}, V_{CE} = V_{CES}, T_J = 25^{\circ}\text{C}$			1	mA
$I_{GES}$	Gate-Emitter Leakage Current	$V_{GE} = \pm 20\text{V}, V_{CE} = 0\text{V}, T_J = 25^{\circ}\text{C}$			100	nA
$C_{ies}$	Input Capacitance	$V_{CE} = 25\text{V}, V_{GE} = 0\text{V}, f = 1\text{MHz}$		13.7		nF
$C_{oes}$	Output Capacitance			0.78		nF

#### Switching Characteristics

$t_{d(on)}$	Turn-on Delay Time	$V_{CC} = 600\text{V}, I_C = 100\text{A}, R_G = 15 \Omega, V_{GE} = \pm 15\text{V},$ Inductive Load	$T_J = 25^{\circ}\text{C}$	245		ns
			$T_J = 125^{\circ}\text{C}$	225		
$t_r$	Rise Time		$T_J = 25^{\circ}\text{C}$	145		ns
			$T_J = 125^{\circ}\text{C}$	145		
$t_{d(off)}$	Turn-off Delay Time		$T_J = 25^{\circ}\text{C}$	420		ns
			$T_J = 125^{\circ}\text{C}$	450		
$t_f$	Fall Time		$T_J = 25^{\circ}\text{C}$	170		ns
			$T_J = 125^{\circ}\text{C}$	230		
$E_{on}$	Turn-on Switching Loss		$T_J = 25^{\circ}\text{C}$	9.1		mJ
			$T_J = 125^{\circ}\text{C}$	11.7		
$E_{off}$	Turn-off Switching Loss	$T_J = 25^{\circ}\text{C}$	5.5		mJ	
		$T_J = 125^{\circ}\text{C}$	7.9			
$Q_g$	Total Gate Charge	$T_J = 25^{\circ}\text{C}$	945		nC	
RBSOA	Reverse Bias Safe Operation Area	$I_C=200\text{A}, V_{CC}=960\text{V}, V_p=1200\text{V}, R_g = 15\Omega, V_{GE}=\pm 15\text{V to } 0\text{V}, T_J = 150^{\circ}\text{C}$	Trapezoid			
SCSOA	Short Circuit Safe Operation Area	$V_{CC} = 600\text{V}, V_{GE} = 15\text{V}, T_J = 150^{\circ}\text{C}$	10		$\mu\text{s}$	
$R_{\theta JC}$	IGBT Thermal Resistance: Junction-To-Case			0.21	$^{\circ}\text{C/W}$	

### Diode, Inverter

#### Maximum Rated Values ( $T_C=25^{\circ}\text{C}$ Unless otherwise specified)

$V_{RRM}$	Repetitive Peak Reverse Voltage	1200	V
$I_F$	Diode Continuous Forward Current	100	A
$I_{FM}$	Diode Maximum Forward Current	200	A

#### Electrical Characteristics of FWD ( $T_C=25^{\circ}\text{C}$ Unless otherwise specified)

Symbol	Description	Conditions	Min	Typ	Max	Unit
$V_{FM}$	Forward Voltage	$I_F = 100\text{ A}$ , $V_{GE} = 0\text{ V}$	$T_J = 25^{\circ}\text{C}$	2.20	2.50	V
			$T_J = 125^{\circ}\text{C}$		2.40	
$I_{rr}$	Peak Reverse Recovery Current		$T_J = 25^{\circ}\text{C}$	40		A
			$T_J = 125^{\circ}\text{C}$		55	
$Q_{rr}$	Reverse Recovery Charge	$I_F=100\text{A}$ , $di/dt = 660\text{A}/\mu\text{s}$ , $V_{rr} = 600\text{V}$ , $V_{GE} = -15\text{V}$	$T_J = 25^{\circ}\text{C}$	4.7		$\mu\text{C}$
			$T_J = 125^{\circ}\text{C}$		10.6	
$E_{rec}$	Reverse Recovery Energy		$T_J = 25^{\circ}\text{C}$	1.5		mJ
			$T_J = 125^{\circ}\text{C}$		3.9	
$R_{\theta JC}$	Diode Thermal Resistance: Junction-To-Case			0.34		$^{\circ}\text{C}/\text{W}$

### IGBT, Brake-Chopper

#### Maximum Rated Values ( $T_C=25^{\circ}\text{C}$ Unless otherwise specified)

$V_{CES}$	Collector-Emitter Blocking Voltage		1200	V
$V_{GES}$	Gate-Emitter Voltage		$\pm 20$	V
$I_C$	Continuous Collector Current	$T_C = 80^{\circ}\text{C}$ ,	50	A
		$T_C = 25^{\circ}\text{C}$	100	A
$I_{CM}$	Peak Collector Current Repetitive	$T_J = 175^{\circ}\text{C}$	100	A
$t_{sc}$	Short Circuit Withstand Time		$>10$	$\mu\text{s}$
$P_D$	Maximum Power Dissipation per IGBT	$T_C = 25^{\circ}\text{C}$ $T_{Jmax}=175^{\circ}\text{C}$	390	W

### Electrical Characteristics of IGBT ( $T_C=25^\circ\text{C}$ Unless otherwise specified)

#### Static characteristics

Symbol	Description	Conditions	Min	Typ	Max	Unit
$V_{GE(th)}$	Gate-Emitter Threshold Voltage	$I_C = 1 \text{ mA}, V_{CE} = V_{GE}$	3.0	4.5	5.0	V
$V_{CE(sat)}$	Collector-Emitter Saturation Voltage	$I_C = 50 \text{ A}, V_{GE} = 15\text{V}$	$T_J = 25^\circ\text{C}$	1.90	2.20	V
			$T_J = 125^\circ\text{C}$	2.20		V
$I_{CES}$	Collector-Emitter Leakage Current	$V_{GE} = 0\text{V}, V_{CE} = V_{CES}, T_J = 25^\circ\text{C}$			1	mA
$I_{GES}$	Gate-Emitter Leakage Current	$V_{GE} = \pm 20\text{V}, V_{CE} = 0\text{V}, T_J = 25^\circ\text{C}$			100	nA
$C_{ies}$	Input Capacitance	$V_{CE} = 25\text{V}, V_{GE} = 0\text{V}, f = 1\text{MHz}$		6.7		nF
$C_{oes}$	Output Capacitance			0.38		nF

#### Switching Characteristics

$t_{d(on)}$	Turn-on Delay Time	$V_{CC} = 600\text{V}, I_C = 50\text{A}, R_G = 15 \Omega, V_{GE} = \pm 15\text{V}, \text{Inductive Load}$	$T_J = 25^\circ\text{C}$	240		ns
			$T_J = 125^\circ\text{C}$	235		
$t_r$	Rise Time		$T_J = 25^\circ\text{C}$	75		ns
			$T_J = 125^\circ\text{C}$	75		
$t_{d(off)}$	Turn-off Delay Time		$T_J = 25^\circ\text{C}$	235		ns
			$T_J = 125^\circ\text{C}$	250		
$t_f$	Fall Time		$T_J = 25^\circ\text{C}$	165		ns
			$T_J = 125^\circ\text{C}$	280		
$E_{on}$	Turn-on Switching Loss		$T_J = 25^\circ\text{C}$	3.72		mJ
			$T_J = 125^\circ\text{C}$	4.48		
$E_{off}$	Turn-off Switching Loss	$T_J = 25^\circ\text{C}$	2.25		mJ	
		$T_J = 125^\circ\text{C}$	3.54			
$Q_g$	Total Gate Charge	$T_J = 25^\circ\text{C}$	260		nC	
RBSOA	Reverse Bias Safe Operation Area	$I_C=100\text{A}, V_{CC}=960\text{V}, V_p=1200\text{V}, R_g = 15\Omega, V_{GE}=\pm 15\text{V to } 0\text{V}, T_J = 150^\circ\text{C}$	Trapezoid			
SCSOA	Short Circuit Safe Operation Area	$V_{CC} = 600\text{V}, V_{GE} = 15\text{V}, T_J = 150^\circ\text{C}$	10		$\mu\text{s}$	
$R_{\theta JC}$	IGBT Thermal Resistance: Junction-To-Case		0.39		$^\circ\text{C/W}$	

### Diode, Brake-Chopper

#### Maximum Rated Values ( $T_C=25^\circ\text{C}$ Unless otherwise specified)

$V_{RRM}$	Repetitive Peak Reverse Voltage	1200	V
$I_F$	Diode Continuous Forward Current	50	A
$I_{FM}$	Diode Maximum Forward Current	100	A

#### Electrical Characteristics of FWD ( $T_C=25^\circ\text{C}$ Unless otherwise specified)

Symbol	Description	Conditions	Min	Typ	Max	Unit
$V_{FM}$	Forward Voltage	$I_F = 50\text{ A}$ , $V_{GE} = 0\text{ V}$	$T_J = 25^\circ\text{C}$	2.00	2.20	V
			$T_J = 125^\circ\text{C}$		2.00	
$I_{rr}$	Peak Reverse Recovery Current		$T_J = 25^\circ\text{C}$	25		A
			$T_J = 125^\circ\text{C}$		40	
$Q_{rr}$	Reverse Recovery Charge	$I_F = 50\text{ A}$ , $di/dt = 700\text{ A}/\mu\text{s}$ , $V_{rr} = 600\text{ V}$ , $V_{GE} = -15\text{ V}$	$T_J = 25^\circ\text{C}$	3.03		$\mu\text{C}$
			$T_J = 125^\circ\text{C}$		6.08	
$E_{rec}$	Reverse Recovery Energy		$T_J = 25^\circ\text{C}$	1.34		mJ
			$T_J = 125^\circ\text{C}$		2.73	
$R_{\theta JC}$	Diode Thermal Resistance: Junction-To-Case			0.49		$^\circ\text{C}/\text{W}$

#### Diode, Rectifier ( $T_C=25^\circ\text{C}$ Unless otherwise specified)

$V_{RRM}$	Repetitive Peak Reverse Voltage	$T_J = 25^\circ\text{C}$	1800	V
$I_{FRMSM}$	Maximum RMS Forward Current per Chip	$T_J = 80^\circ\text{C}$	100	A
$I_{RMSM}$	Maximum RMS Current at Rectifier Output	$T_J = 80^\circ\text{C}$	150	A
$I_{FSM}$	Surge Current @ $t_p=10\text{ ms}$	$T_J = 25^\circ\text{C}$	1200	A
		$T_J = 150^\circ\text{C}$	900	
$I^2t$	$I^2t$ - value	$T_J = 25^\circ\text{C}$	6700	$\text{A}^2\text{s}$
		$T_J = 150^\circ\text{C}$	3900	

### Electrical Characteristics of Diode ( $T_C=25^{\circ}\text{C}$ Unless otherwise specified)

Symbol	Description	Conditions		Min	Typ	Max	Unit
$V_F$	Forward voltage	$I_F = 100\text{ A}$ ,	$T_J = 25^{\circ}\text{C}$		1.15		V
			$T_J = 150^{\circ}\text{C}$		1.10		
$I_R$	Reverse current	$V_R = 1200\text{V}$	$T_J = 25^{\circ}\text{C}$			1	mA
$R_{\theta JC}$	Diode Thermal Resistance: Junction-To-Case				0.34		$^{\circ}\text{C}/\text{W}$

### Internal NTC-Thermistor Characteristic

Symbol	Description	Min	Typ	Max	Unit
$R_{25}$	$T_C = 25^{\circ}\text{C}$		5		k $\Omega$
$\Delta R/R$	$T_C = 100^{\circ}\text{C}$ , $R_{100} = 481\Omega$			$\pm 5$	%
$P_{25}$	$T_C = 25^{\circ}\text{C}$		50		mW
$B_{25/50}$	$R_2 = R_{25} \exp[B_{25/50}(1/T_2 - 1/(298.15\text{K}))]$		3380		K
$B_{25/80}$	$R_2 = R_{25} \exp[B_{25/80}(1/T_2 - 1/(298.15\text{K}))]$		3440		K

### Module

Symbol	Description		Min	Typ	Max	Unit
$V_{iso}$	Isolation Voltage(All Terminals Shorted)	$f = 50\text{Hz}$ , 1minute			2500	V
$T_J$	Maximum Junction Temperature				175	$^{\circ}\text{C}$
$T_{JOP}$	Maximum Operating Junction Temperature Range		-40		+150	$^{\circ}\text{C}$
$T_{stg}$	Storage Temperature		-40		+125	$^{\circ}\text{C}$
$R_{\theta CS}$	Case-To-Sink (Conductive Grease Applied)			0.1		$^{\circ}\text{C}/\text{W}$
T	Mounting Screw:M5		4.0		6.0	N·m
G	Weight			300		g

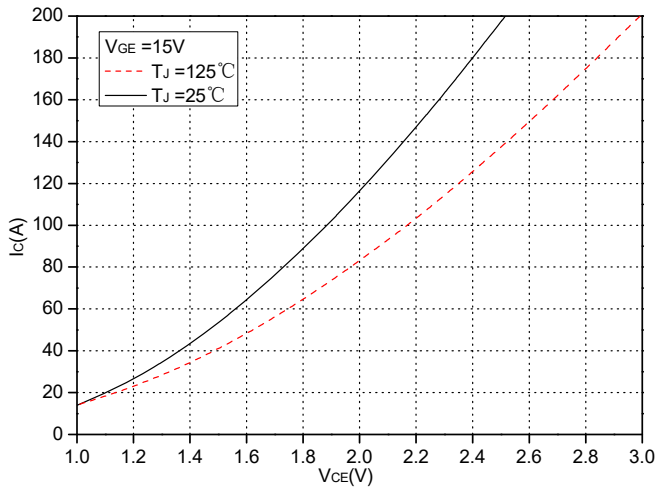

Fig.1 Typical Saturation Voltage Characteristics (Inverter)

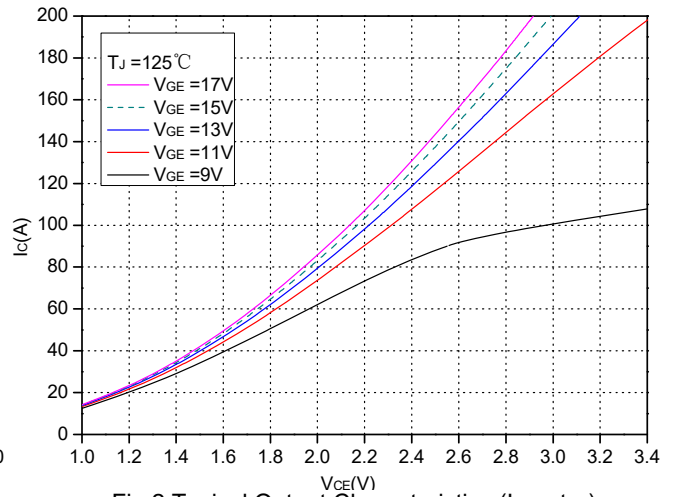

Fig.2 Typical Output Characteristics (Inverter)

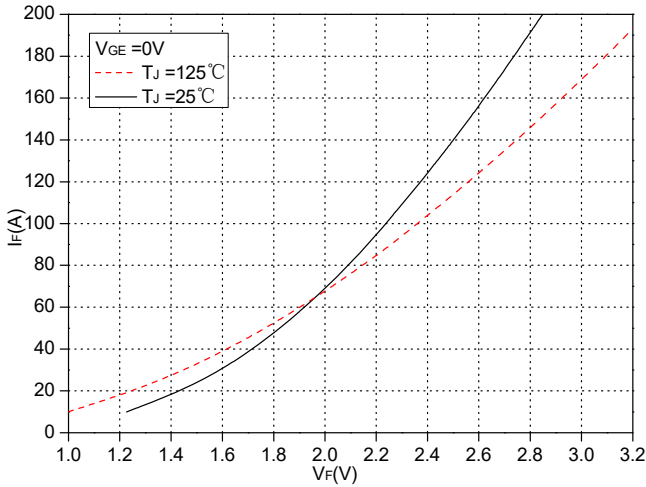

Fig.3 Forward Characteristics of FWD (Inverter)

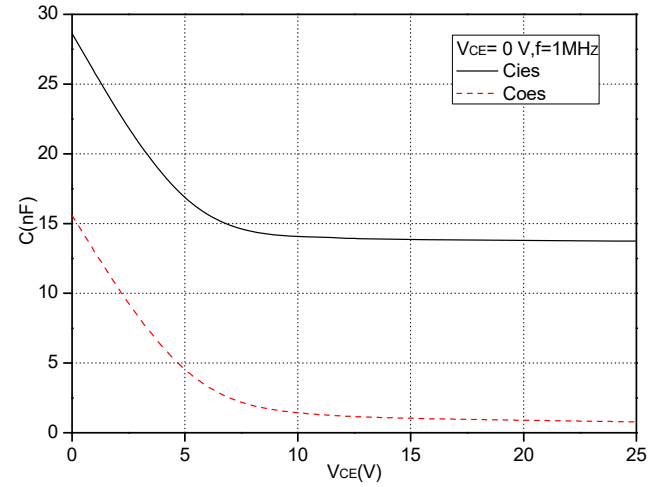

Fig.4 Capacitance Characteristics

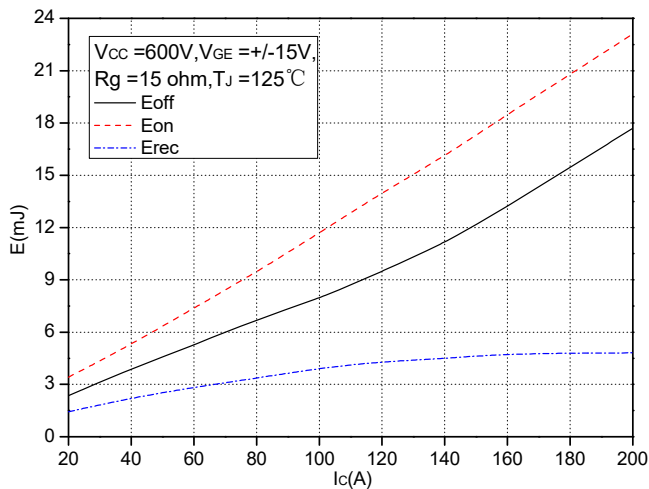

Fig.5 Typical Switching Loss vs. Collector Current (Inverter)

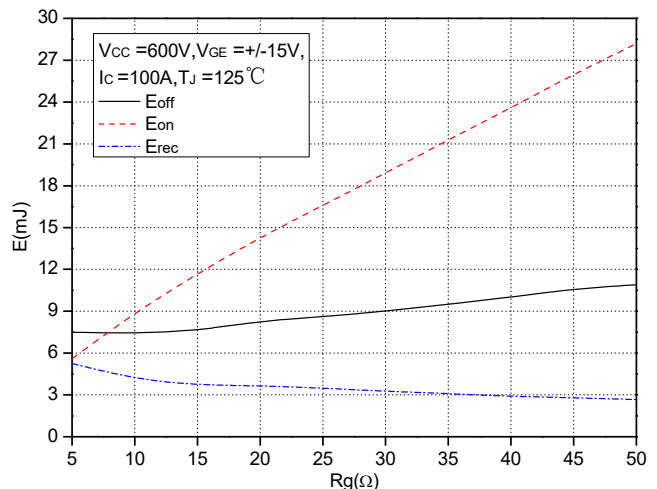

Fig.6 Typical Switching Loss vs. Gate Resistance (Inverter)

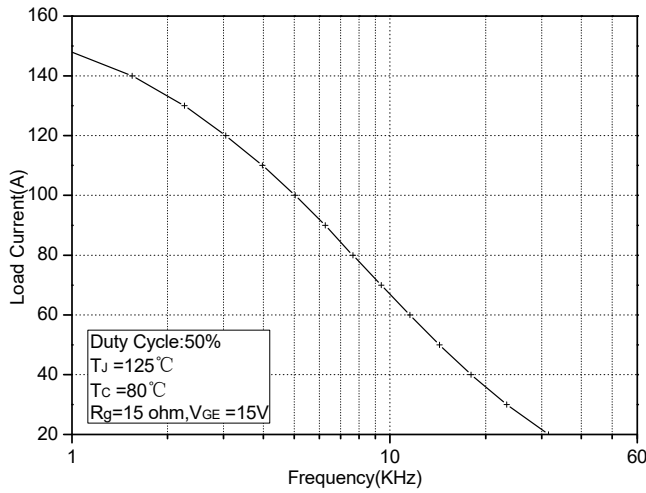

Fig.7 Typical Load Current vs. Frequency (Inverter)

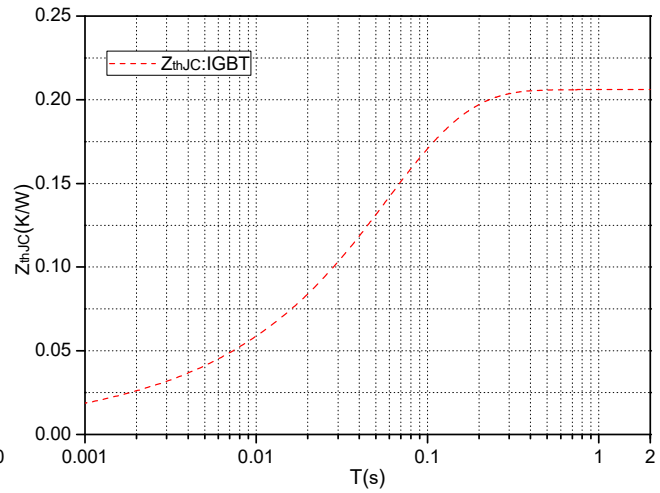

Fig.8 Transient Thermal Impedance IGBT (Inverter)

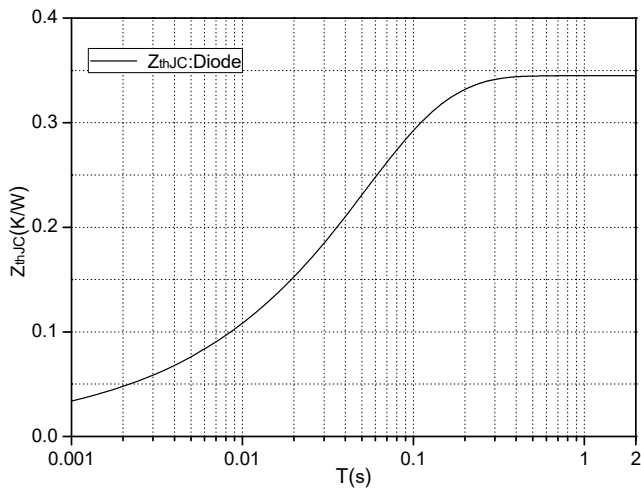

Fig.9 Transient thermal impedance Diode (Inverter)

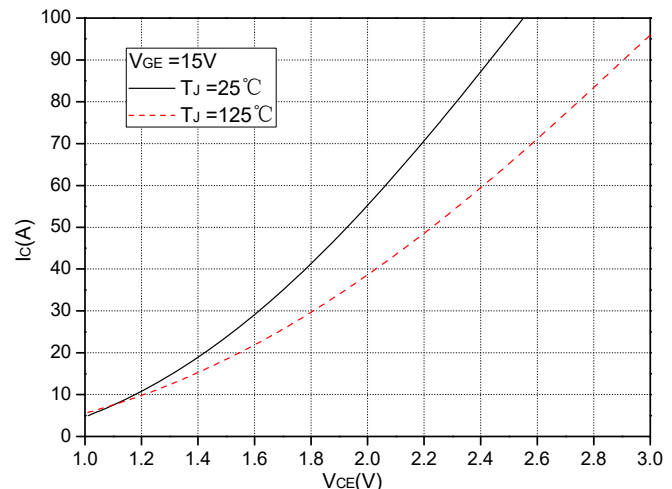

Fig.10 Typical Saturation Voltage Characteristics (Brake-Chopper)

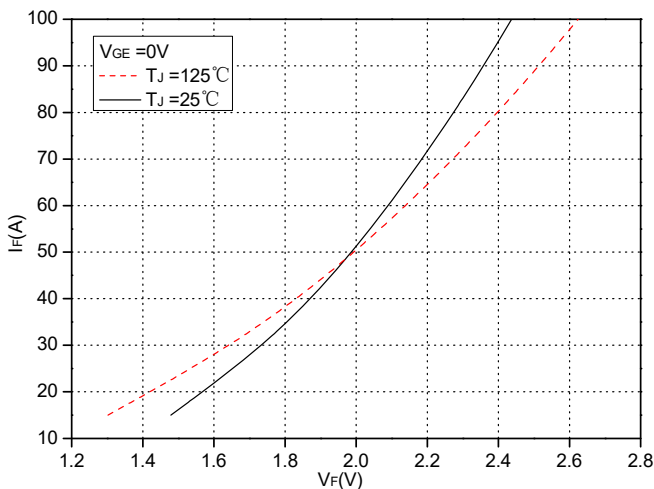

Fig.11 Forward Characteristics of FWD (Brake-Chopper)

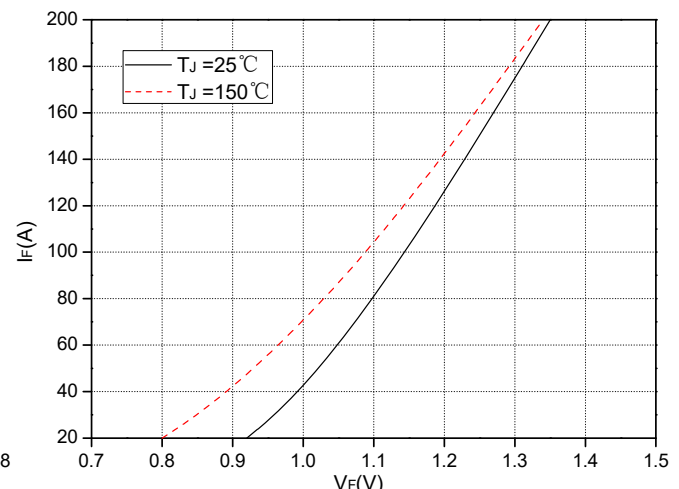

Fig.12 Forward Characteristics of Diode (Rectifier)



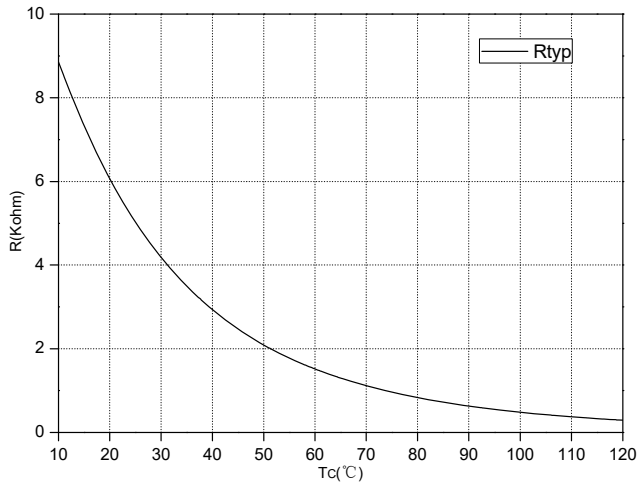

Fig.13 NTC Temperature characteristics

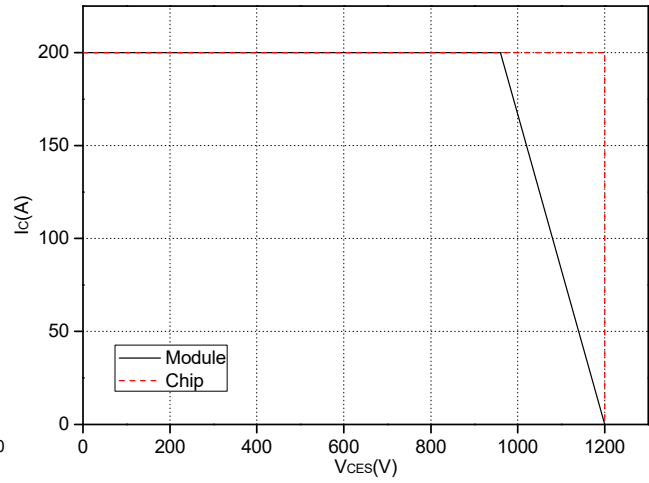
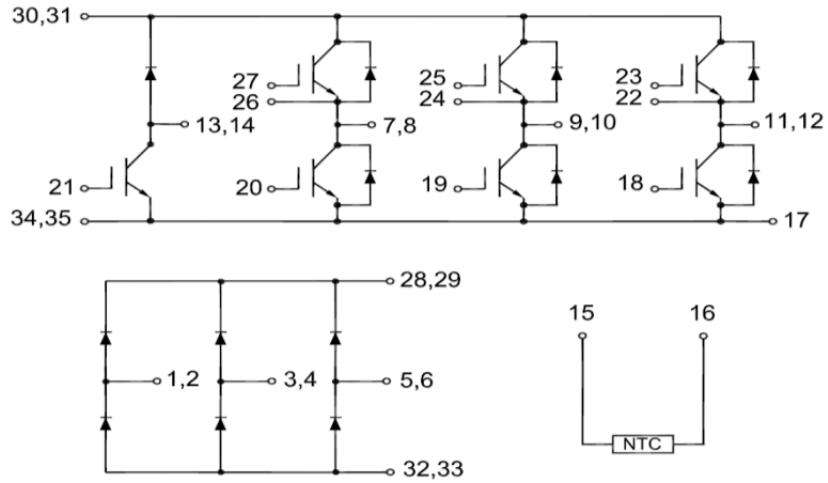
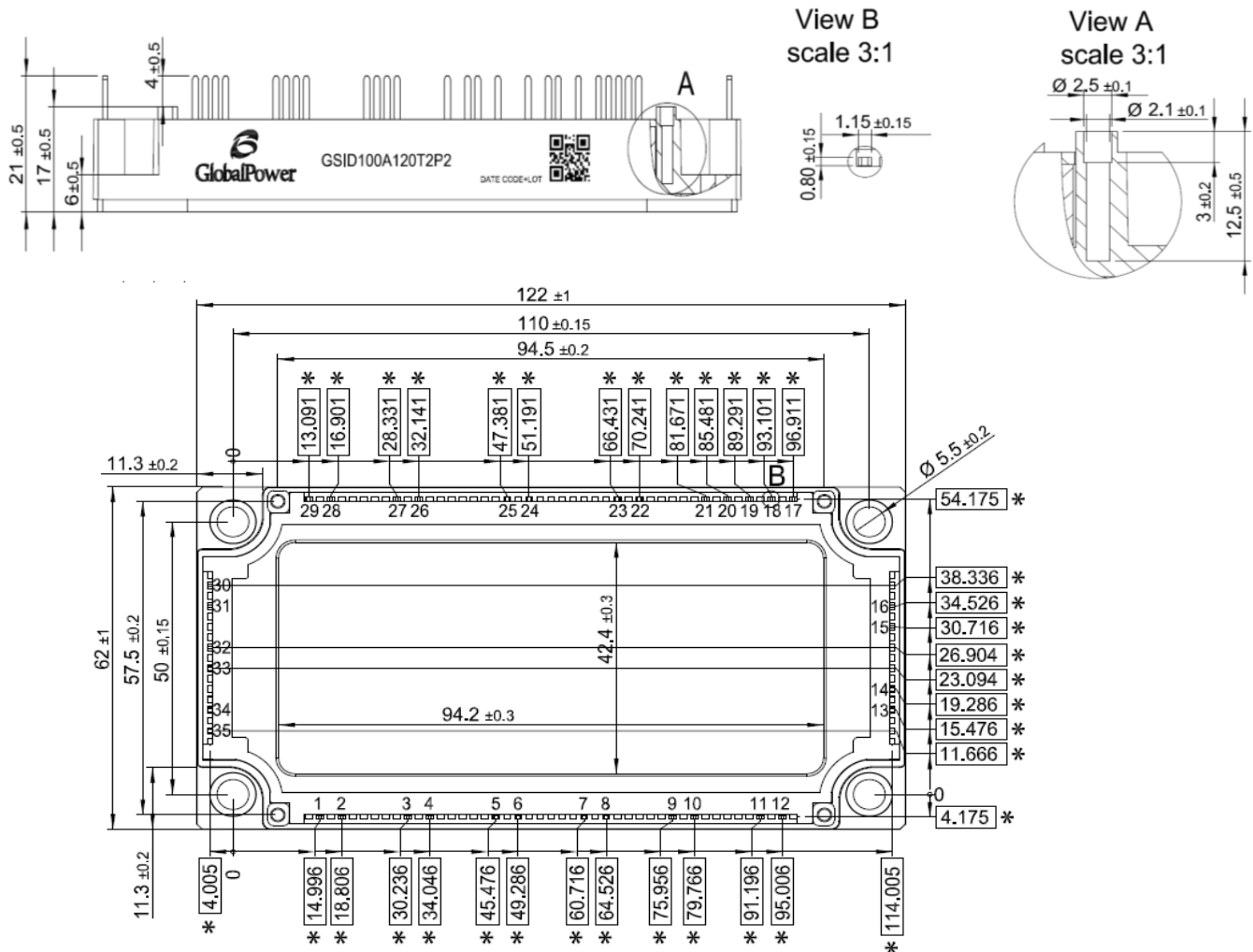

Fig.14 Reverse Bias Safe Operation Area (RBSOA)

### Internal Circuit:



### Package Outline (Unit: mm):



### Revision History

Date	Revision	Notes
4/13/2015	1.0	Initial release
01/03/2020	1.1	Applied company name change

#### Notes

##### **RoHS Compliance**

The levels of RoHS restricted materials in this product are below the maximum concentration values (also referred to as the threshold limits) permitted for such substances, or are used in an exempted application, in accordance with EU Directive 2011/65/EC (RoHS2), as implemented March, 2013. RoHS Declarations for this product can be obtained from the Product Documentation sections of [www.SemiQ.com](http://www.SemiQ.com).

##### **REACH Compliance**

REACH substances of high concern (SVHC) information is available for this product. Since the European Chemicals Agency (ECHA) has published notice of their intent to frequently revise the SVHC listing for the foreseeable future, please contact our office at SemiQ Headquarters in Lake Forest, California to insure you get the most up-to-date REACH SVHC Declaration. REACH banned substance information (REACH Article 67) is also available upon request.

SemiQ Inc., reserves the right to make changes to the product specifications and data in this document without notice. SemiQ products are sold pursuant to SemiQ's terms and conditions of sale in place at the time of order acknowledgement.

This product has not been designed or tested for use in, and is not intended for use in, applications implanted into the human body nor in applications in which failure of the product could lead to death, personal injury or property damage, including but not limited to equipment used in the operation of nuclear facilities, life-support machines, cardiac defibrillators or similar emergency medical equipment, aircraft navigation or communication or control systems, or air traffic control.

SemiQ makes no warranty, representation or guarantee regarding the suitability of its products for any particular purpose, nor does SemiQ assume any liability arising out of the application or use of any product or circuit, and specifically disclaims any and all liability, including without limitation special, consequential or incidental damages. Buyer is responsible for its products and applications using SemiQ products.

To obtain additional technical information or to place an order for this product, please contact us. The information in this datasheet is provided by SemiQ. SemiQ reserves the right to make changes, corrections, modifications, and improvements of datasheet without notice.