

**TOP VIEW**

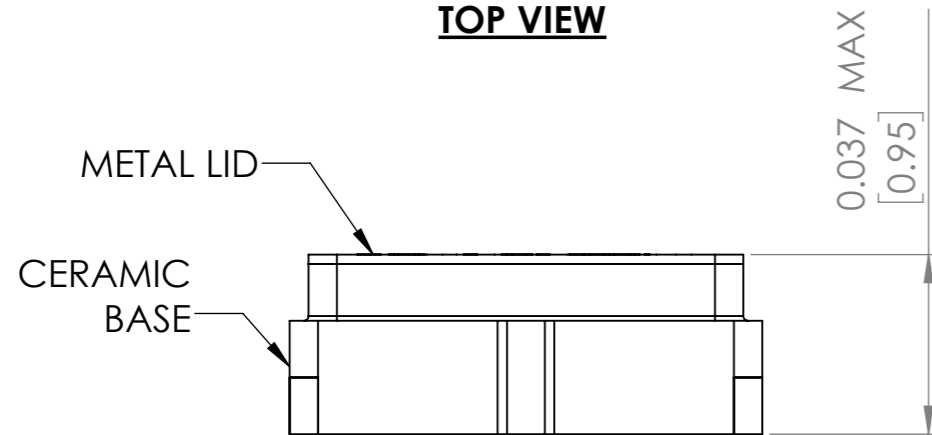

**SIDE VIEW**

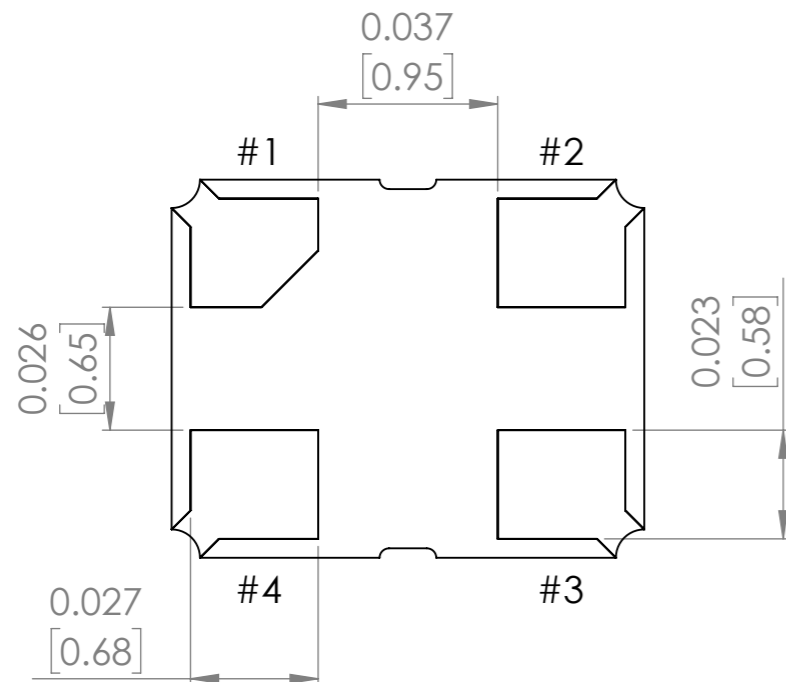

**BOTTOM VIEW**

**DIMENSIONS: INCHES[MM]**

**Recommended Land Pattern**

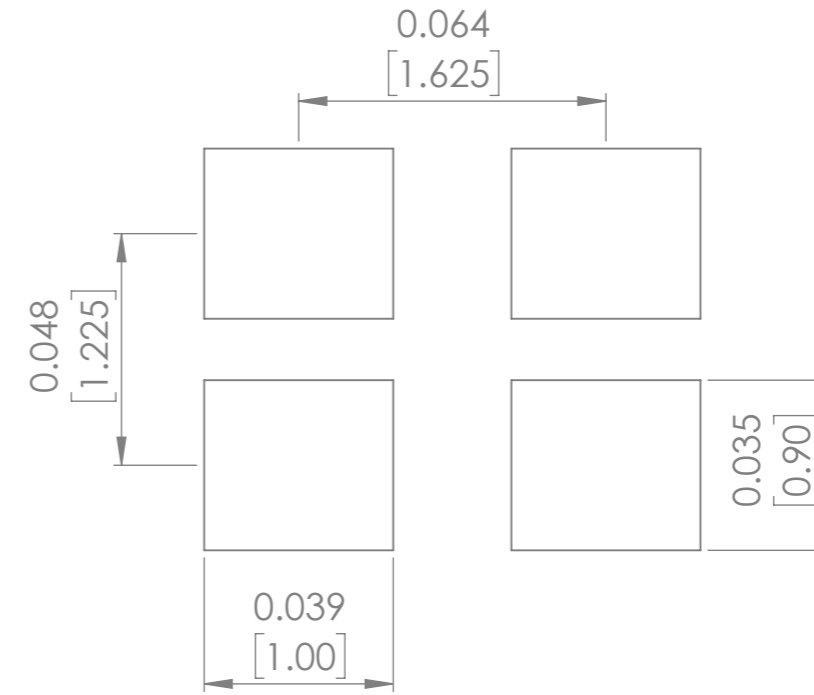

Pin #	Function
1	Tri-state
2	GND/Case
3	Output
4	V <sub>dd</sub>

Note: Recommend using an approximately 0.01uF bypass capacitor between PIN 2 and PIN4

**TOP PACKAGE MARKING IS FOR ILLUSTRATION PURPOSES ONLY**

DO NOT SCALE DRAWING		REVISION	-
			
5101 Hidden Creek Lane, Spicewood Texas-78669			
TITLE:			
DWG NO.	ASDKDVAIG		A3
SCALE: 25:1	SHEET 1 OF 1		