

- *Miniature High Performance SAW Filter*
- *Low Passband Loss*
- *Hermetic 1.4 x 1.1 mm Surface-mount Case*
- *Complies with Directive 2002/95/EC (RoHS)*

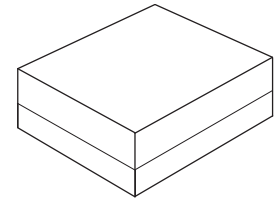

SF2316K-1

**1588.655 MHz
SAW Filter**



SM1411-5

Absolute Maximum Ratings

Rating	Value	Units
Maximum Incident Power in Passband	+10	dBm
Maximum DC Voltage On any Non-ground Terminal	3	VDC
Component Operating Temperature Range	-40 to +105	°C
Storage Temperature Range in Tape and Reel	-40 to +105	°C
Maximum Soldering Temperature Profile (5 cycles maximum)	265 °C for 10 s	
Moisture Sensitivity Level: 2A		

Electrical Characteristics

Characteristic	Sym	Notes	Min	Typ	Max	Units
Center Frequency	f_c		1588.655			MHz
Insertion Loss, 1573.42 to 1577.42 MHz	IL_{MAX}			1.25	1.90	dB
Insertion Loss, 1571.42 to 1605.89 MHz				1.85	2.50	
Amplitude Ripple, 1573.42 to 1577.42 MHz				0.25	1.20	dB
Amplitude Ripple, 1571.42 to 1605.89 MHz				0.80	1.50	
Attenuation						dB
DC to 824 MHz			32	36		
824 to 849 MHz			32	36		
849 to 880 MHz			32	36		
880 to 915 MHz			32	36		
915 to 1452 MHz			32	36		
1452 to 1525 MHz			35	39		
1710 to 1785 MHz			35	38		
1785 to 1850 MHz			30	37		
1850 to 6000 MHz			25	37		
I/O VSWR, 1573.42 to 1577.42 MHz				1.9	2.3	
I/O VSWR, 1571.42 to 1605.89 MHz				2.0	2.3	
Temperature Coefficient of Frequency	ppm/°C			-36		
Case Style			SM1411-5			
Lid Symbolization			R			



CAUTION: Electrostatic Sensitive Device. Observe precautions for handling.

NOTES:

1. The design, manufacturing process, and specifications of this device are subject to change.
2. US or International patents may apply.
3. RoHS compliant from the first date of manufacture.

Frequency Response Plots

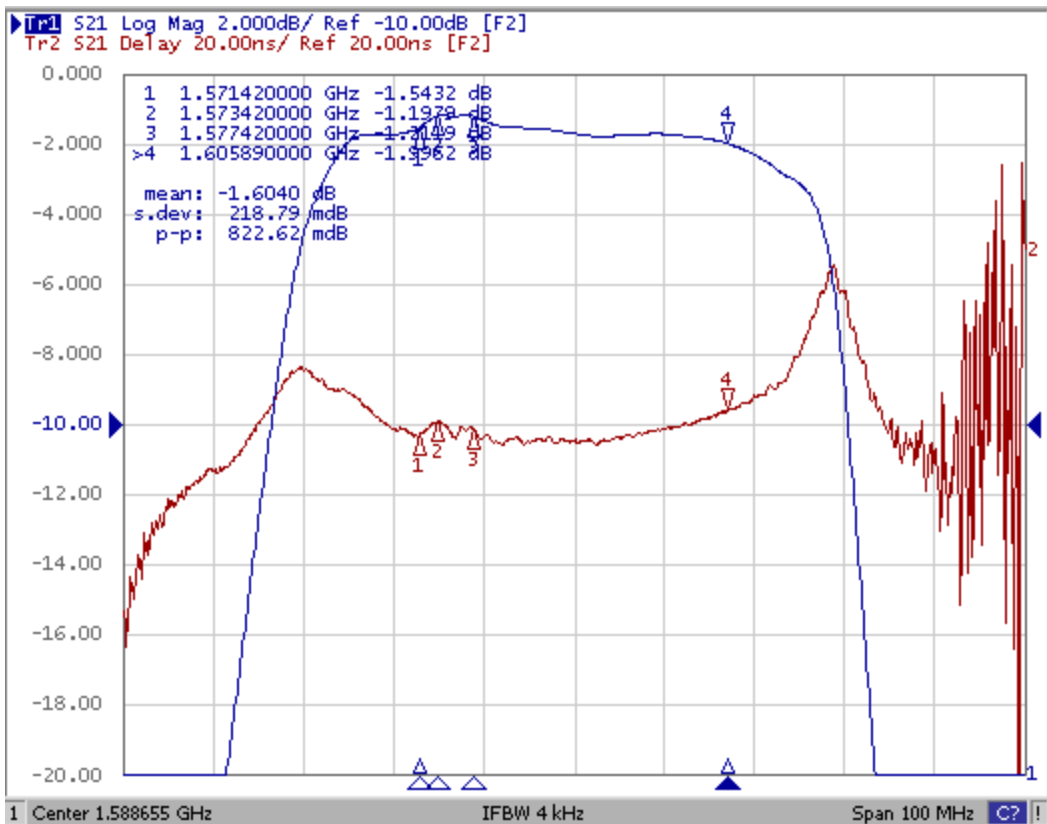
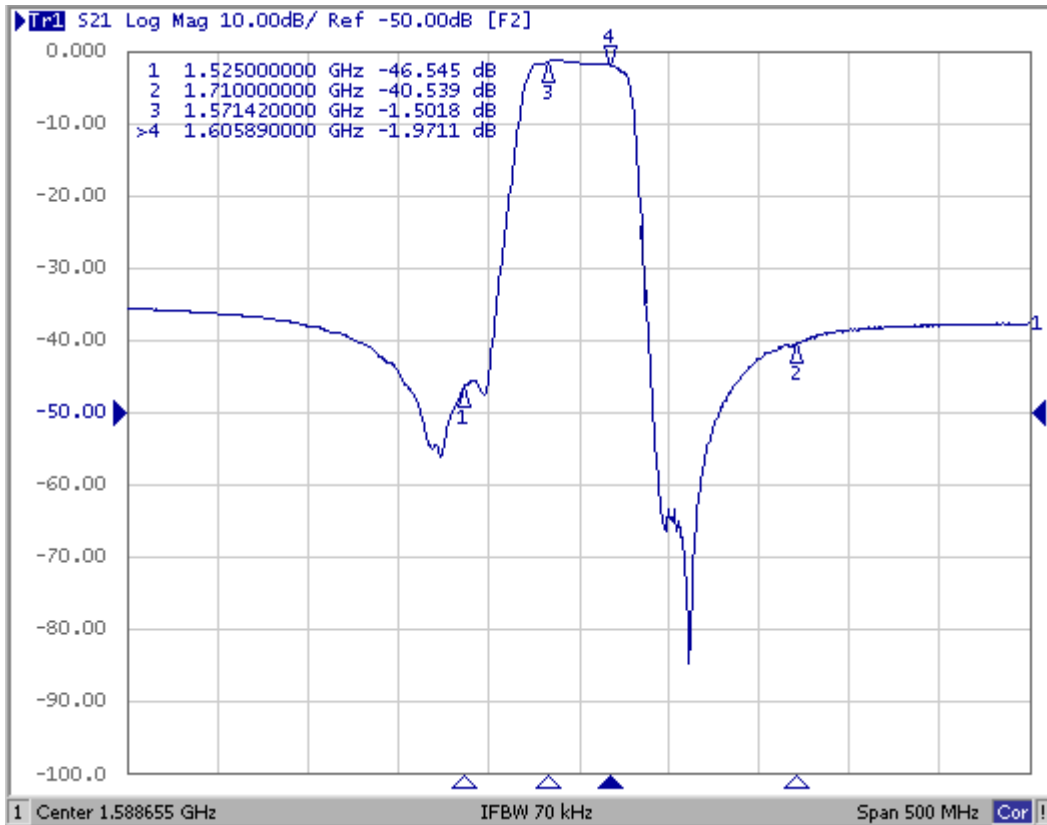

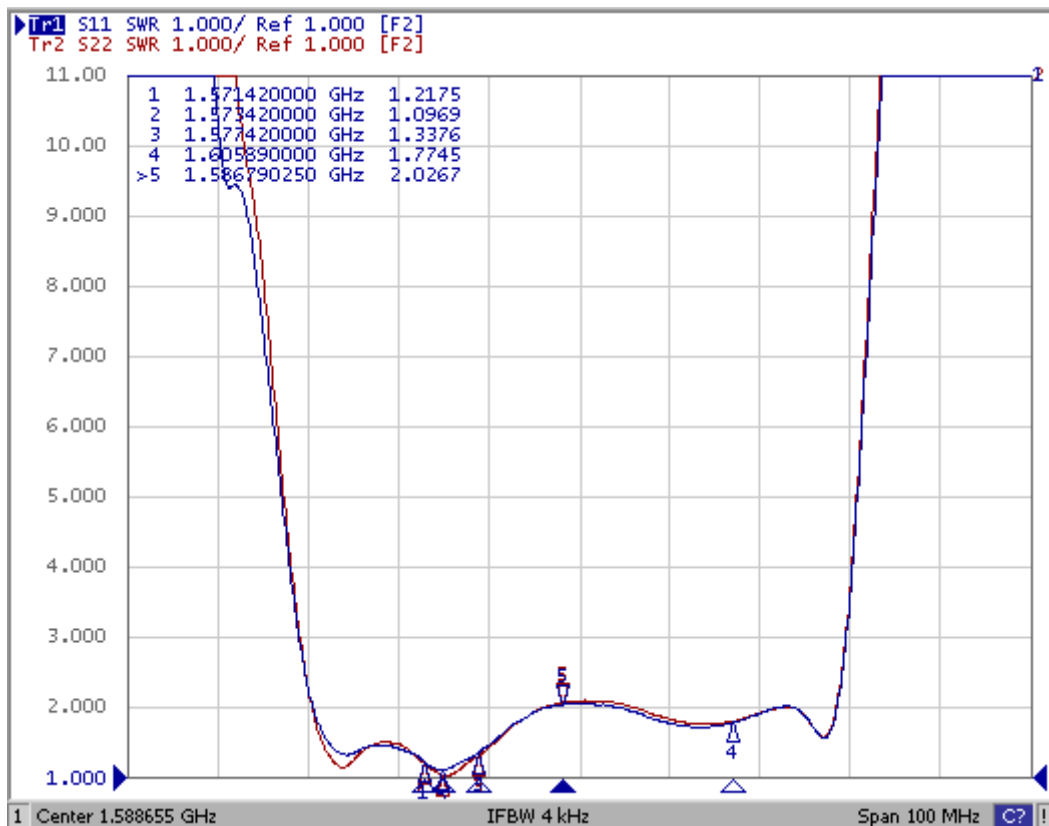
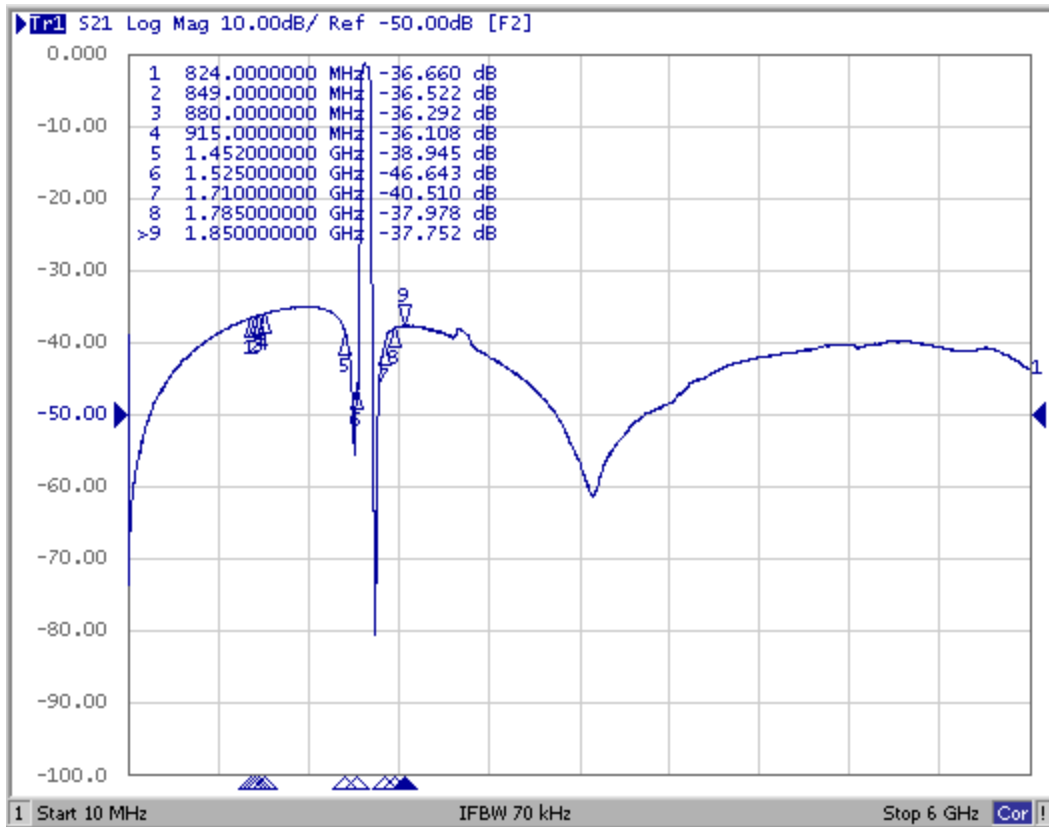

SM1411-5 1.4 X 1.1 mm 5-Terminal Surface-mount Case

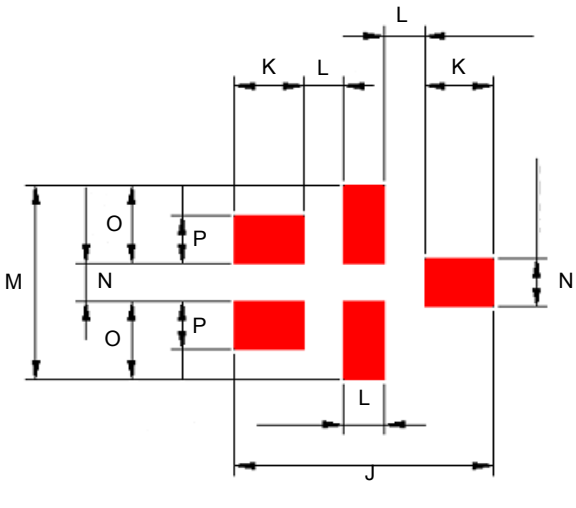
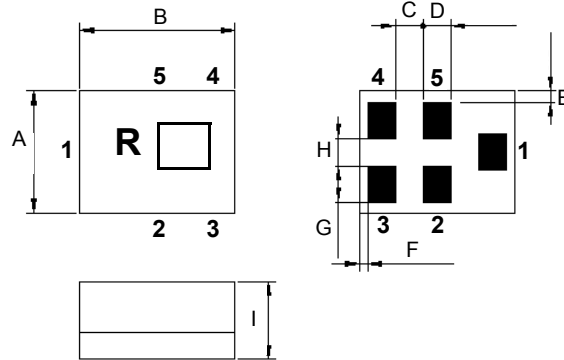

Dimension	mm			Inches		
	Min	Nom	Max	Min	Nom	Max
A	-	1.10	-	-	0.043	-
B	-	1.40	-	-	0.055	-
C	-	0.25	-	-	0.009	-
D	-	0.25	-	-	0.009	-
E	-	0.10	-	-	0.003	-
F	-	0.075	-	-	0.002	-
G	-	0.325	-	-	0.012	-
H	-	0.25	-	-	0.009	-
I	-	-	0.700	-	-	0.027
J	-	1.60	-	-	0.062	-
K	-	0.425	-	-	0.016	-
L	-	0.25	-	-	0.009	-
M	-	1.30	-	-	0.051	-
N	-	0.325	-	-	0.012	-
O	-	0.525	-	-	0.020	-
P	-	0.325	-	-	0.012	-

PCB Footprint

Materials	
Solder Pad Plating	0.3 to 1.0 μm Gold over 1.27 to 8.89 μm Nickel
Body	Al_2O_3 Ceramic
Pb Free	

Test Circuit

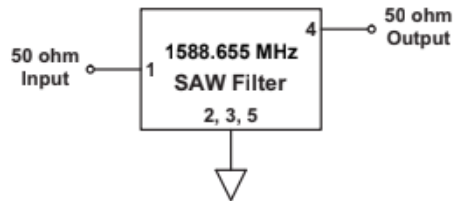

Reel Dimensions - 7 inch Reel, 3000 Filters

Tape and Reel Standard per ANSI/EIA-481

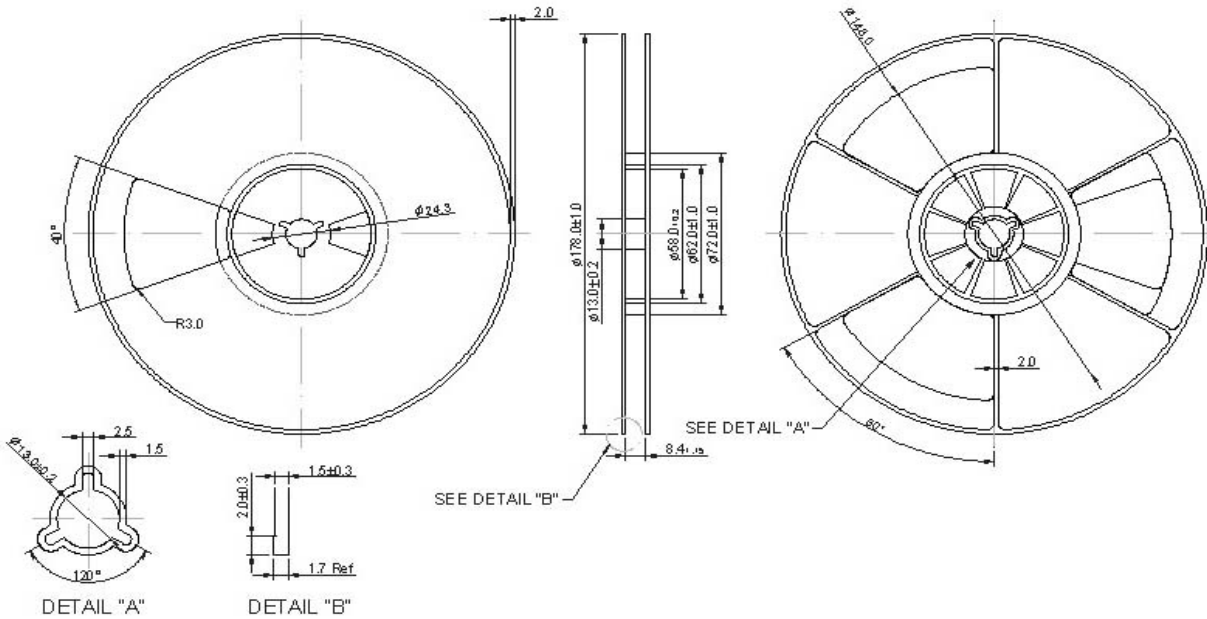

Tape Dimensions

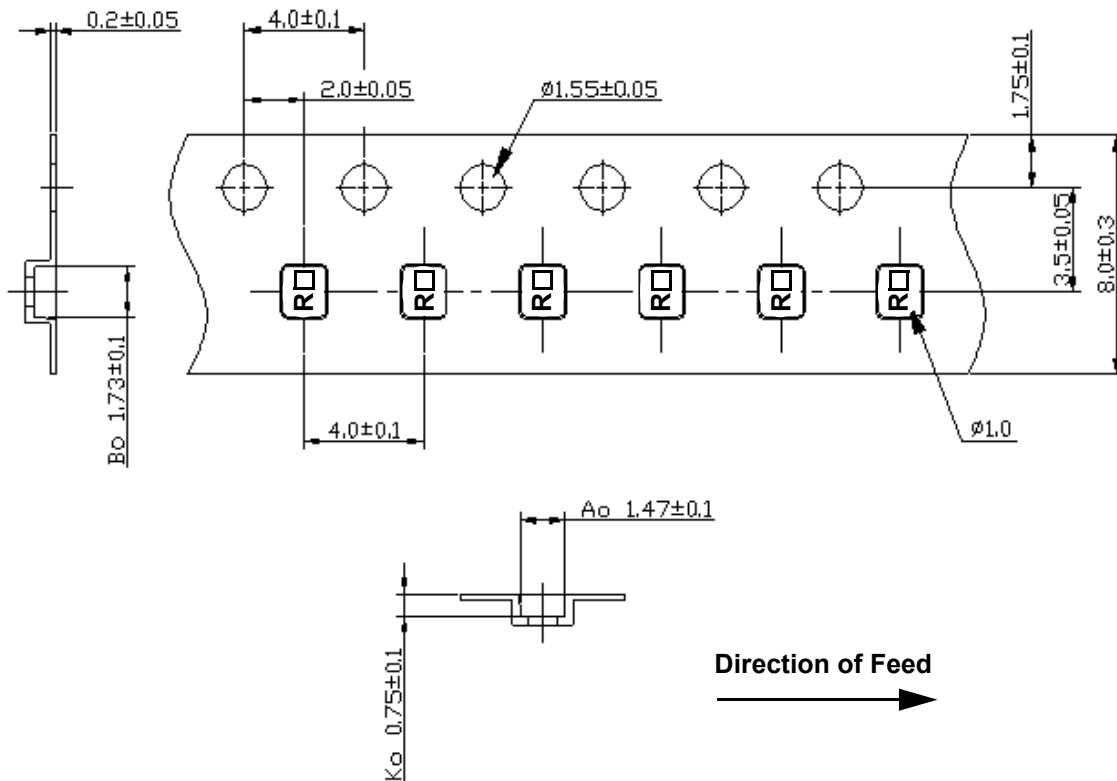

Recommended Reflow Profile

1. Preheating shall be fixed at 150~180°C for 60~90 seconds.
2. Ascending time to preheating temperature 150°C shall be 30 seconds min.
3. Heating shall be fixed at 220°C for 50~80 seconds and at 260°C +0/-5°C peak (10 seconds).
4. Time: 5 times maximum.

